

TWIN/FULL BUNK BED

Model Number:	UPC Code:	Color:
DA7499E	0-65857-17298-0	Espresso
DA7499W	0-65857-17299-7	White
DA7499G	0-65857-17755-8	Gray

Congratulations on your latest furniture purchase! **Dorel Living** furniture has been developed with quality, convenience and style in mind. We trust it will provide you with many years of exceptional comfort and service.

Before beginning assembly, we encourage you to familiarize yourself with your new furniture piece by taking a few minutes to go through this booklet. It contains important information on our warranty and care tips to keep your furniture looking as good as new.

For more great furniture ideas, check out our website at www.dorelliving.com

You can also keep up to date on all the latest trends by liking our [Facebook page](#) and [Instagram page](#).

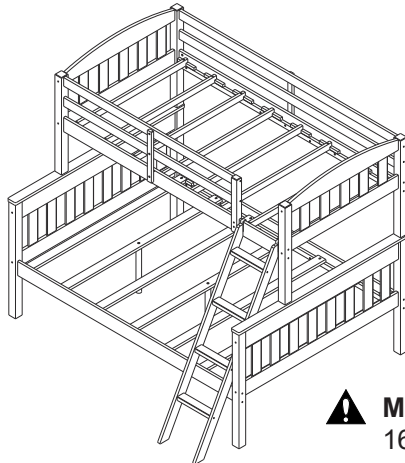

<small>Distributed by / Distribué par:</small> Dorel Asia Inc. 410 East First Street, South, Wright City, MO, USA 63390	
Model / Modèle:	DA7499E / DA7499W DA7499G
Factory / Usine:	136832
Date of / de Production:	2021/01
IM #:	B34DA7499001
Color:	Espresso/White Gray
<small>Made in Brazil / Fabriqué au Brésil</small>	

 **Maximum Weight :**
165 lb / 75 kg Per level

Date of Purchase: ____ / ____ / ____

Lot Number: _____

(located on carton)

Instruction Manual number : B34DA7499001 - 136832

Questions, concerns, missing parts? Customer satisfaction is important to us at Dorel
**CONTACT OUR CUSTOMER SERVICE DEPARTMENT BEFORE RETURNING
PRODUCT TO THE RETAILER.**

cs@dhpffurniture.com

1-800-267-1739

Monday to Friday 9:00 am to 9:00 pm (Eastern Time)

Saturday 10 am to 6:30 pm (Eastern Time)

Sunday 11 am to 7 pm (Eastern Time)

DHP Consumer Services

12345 Albert-Hudon Boulevard, Suite 100

Montreal, Québec, Canada, H1G 3L1

NOTE: THIS INSTRUCTION BOOKLET CONTAINS **IMPORTANT** SAFETY INFORMATION. PLEASE
READ AND KEEP FOR FUTURE REFERENCE.

CUSTOMER SERVICE

You can also contact us by writing to the address listed below. Please include the product model number, color and a detailed description of your enquiry.

Dorel Living - Customer Service Department
12345 Albert-Hudon Boulevard, Suite 100
Montreal, Quebec
Canada, H1G 3L1

NOTES AND INSTALLATION

- READ EACH STEP CAREFULLY BEFORE STARTING. IT IS VERY IMPORTANT THAT EACH STEP OF INSTRUCTION IS PERFORMED IN THE CORRECT ORDER. IF THESE STEPS ARE NOT FOLLOWED IN SEQUENCE, ASSEMBLY DIFFICULTIES WILL OCCUR AND CAN RESULT IN INJURY.
- **CAUTION:**ADULT ASSEMBLY REQUIRED.
- MAKE SURE ALL PARTS ARE INCLUDED. WORK IN SPACIOUS AREA, PREFERABLY ON A SMOOTH SOFT SURFACE.
- ASSEMBLY WILL REQUIRE TWO PEOPLE.
- MOST BOARD PARTS ARE LABELED OR STAMPED ON THE RAW EDGE.
- PHILLIPS SCREWDRIVER (NOT INCLUDED) IS REQUIRED.
- A RUBBER Mallet (NOT INCLUDED) IS RECOMMENDED TO FACILITATE ASSEMBLY.
- BED IS DESIGNED FOR CHILDREN RANGING FROM 6 YEARS OF AGE TO YOUNG TEENAGERS.

CARE, CLEANING AND MAINTENANCE

Dust regularly with a soft, dry cloth. We do not recommend the use of chemical cleaners or wax on our lacquered furniture as it may damage the finish. Keep solvents, alcohol, nail polish and polish removers away from your hardwood furniture surfaces.

Check bolts/screws periodically and tighten them if necessary.

1-YEAR LIMITED WARRANTY

Dorel warrants its product to be free from defects in material and workmanship and agrees to remedy any such defect. This warranty covers 1 year from the date of original purchase from authorized retailers. This warranty is valid only upon presentation of proof of purchase. This is solely limited to the repair or replacement of defective furniture components and no assembly labor is included. This warranty does not apply to any product which has been improperly assembled, subjected to misuse or abuse or which has been altered or repaired in any way. The warranty does not cover wearing, tearing, fading or splitting of the fabric (where applicable). This warranty gives you specific legal rights and you may also have other rights which vary from State to State or Province to Province.



WARNING: Should this product become damaged, and/or components are broken or missing, DO NOT USE.





WARNING - Bunk bed: Twin / Full

- **STRANGULATION HAZARD** - Never attach or hang items to any part of the bunk bed that are not designed for use with the bed; for example, but not limited to, hooks, belts and jump ropes.
- Follow the information on the warnings appearing on the upper bunk end structure and on the carton. Do not remove warning label from bed.
- The mattress platform is designed to support a mattress without the need for a posture board or box spring.
- Always use the recommended size of mattresses or mattress supports, or both, to help prevent the likelihood of entrapment or falls.
- **USE ONLY A COIL SPRING MATTRESS ON BOTH THE UPPER AND LOWER BUNKS. FAILURE TO DO SO CAN RESULT IN INJURY.**
- Use only mattresses which are **74"-75"** long and **37 1/2" - 38 1/2"** wide on the upper bed and **74"-75"** long and **53"-54"** wide on upper on the lower lower bed. Ensure thickness of mattress does not exceed **6"**. Surface of mattress must be at least **5" (127 mm)** below the upper edge of guardrails.
- Do not allow children under **6** years of age to use the upper bunk.
- Always use guardrails on both long sides of the upper bunk. If the bunk bed will be placed next to the wall, the guardrail that runs the full length of the bed should be placed against the wall to prevent entrapment between the bed and wall (applicable for bunk beds with full length guardrails on one side).
- Periodically check and ensure that the guardrail, ladder, and other components are in their proper position, free from damage, and that all connectors are tight.
- Do not allow horseplay on or under the bed and prohibit jumping on the bed.
- Do not use substitute parts. Contact the manufacturer or dealer for replacement parts.
- Use of a night light may provide added safety precaution for a child using the upper bunk.
- The use of water or sleep flotation mattresses is prohibited.
- Always use the ladder for entering and leaving the upper bunk.
- Prohibit more than one person on upper bunk.
- Keep these instructions for future reference.

TWIN/FULL BUNK BED

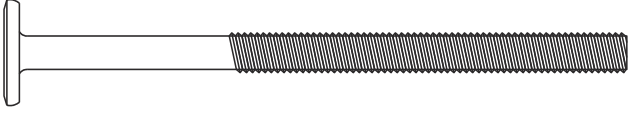
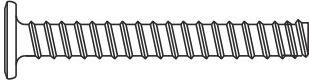
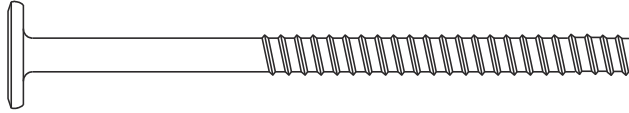
DA7499E / DA7499W / DA7499G

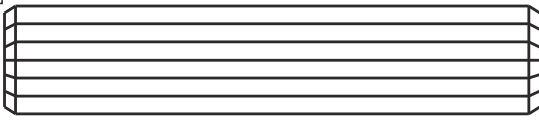
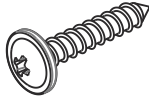
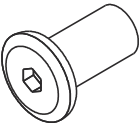
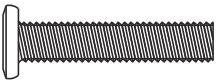
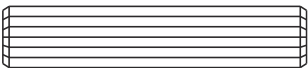
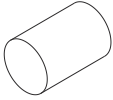
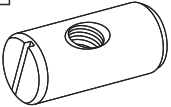
HARDWARELIST



<p>1</p>  <p>Ø1/4" x 100mm</p> <p>JOINT CONNECTOR (4mm HEX HEAD) 16 PCS</p>	<p>2</p>  <p>Ø6.5mm x 48mm</p> <p>WOOD JOINT CONNECTOR (4mm HEX HEAD) 8 PC</p>		
<p>3</p>  <p>Ø6.5mm x 100mm</p> <p>WOOD JOINT CONNECTOR (4mm HEX HEAD) 24 PCS</p>	<p>4</p>  <p>Ø4mm x 35mm</p> <p>FLAT HEAD WOOD SCREW 26 PCS</p>		
<p>5</p>  <p>Ø15mm x 100mm WOOD DOWEL 4 PCS</p>	<p>6</p>  <p>4mm x 35mm FLANG HEAD WOOD SCREW 6 PCS</p>		
<p>7</p>  <p>Ø9mm x 17mm</p> <p>HEX CAP 2 PCS</p>	<p>8</p>  <p>Ø1/4" x 32mm</p> <p>HEX SOCKET HEAD BOLT 5 PCS</p>	<p>9</p>  <p>Ø10mm x 50mm</p> <p>WOOD DOWEL 44 PCS</p>	<p>10</p>  <p>STOPPER 26 PCS</p>
<p>11</p>  <p>Ø11.8mm x 15mm</p> <p>BARREL NUT 16 PCS</p>	<p>12</p>  <p>Ø4mm x 19mm</p> <p>FLAT HEAD SCREW 2 PCS</p>	<p>13</p>  <p>ALLEN KEY 1 PC</p>	

TWIN/FULL BUNK BED

DA7499E / DA7499W / DA7499G

Hardware Pack





DA7499G (Gray) DA7499E (Espresso)	HP#: <input checked="" type="checkbox"/> TDA7499E-00
DA7499W (White)	HP#: <input type="checkbox"/> TDA7499W-00

-  Please do not completely tighten all the hardware, until the entire assembly is complete, unless otherwise indicated in the step-by-step instructions.
-  The screw(s), bolt(s) to be used at each step are shown in actual size in the lower right corner of the page.

TWIN/FULL BUNK BED

DA7499E / DA7499W / DA7499G

PARTS LIST

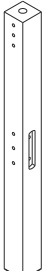
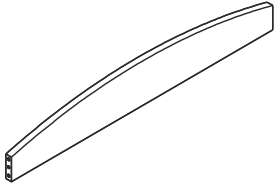

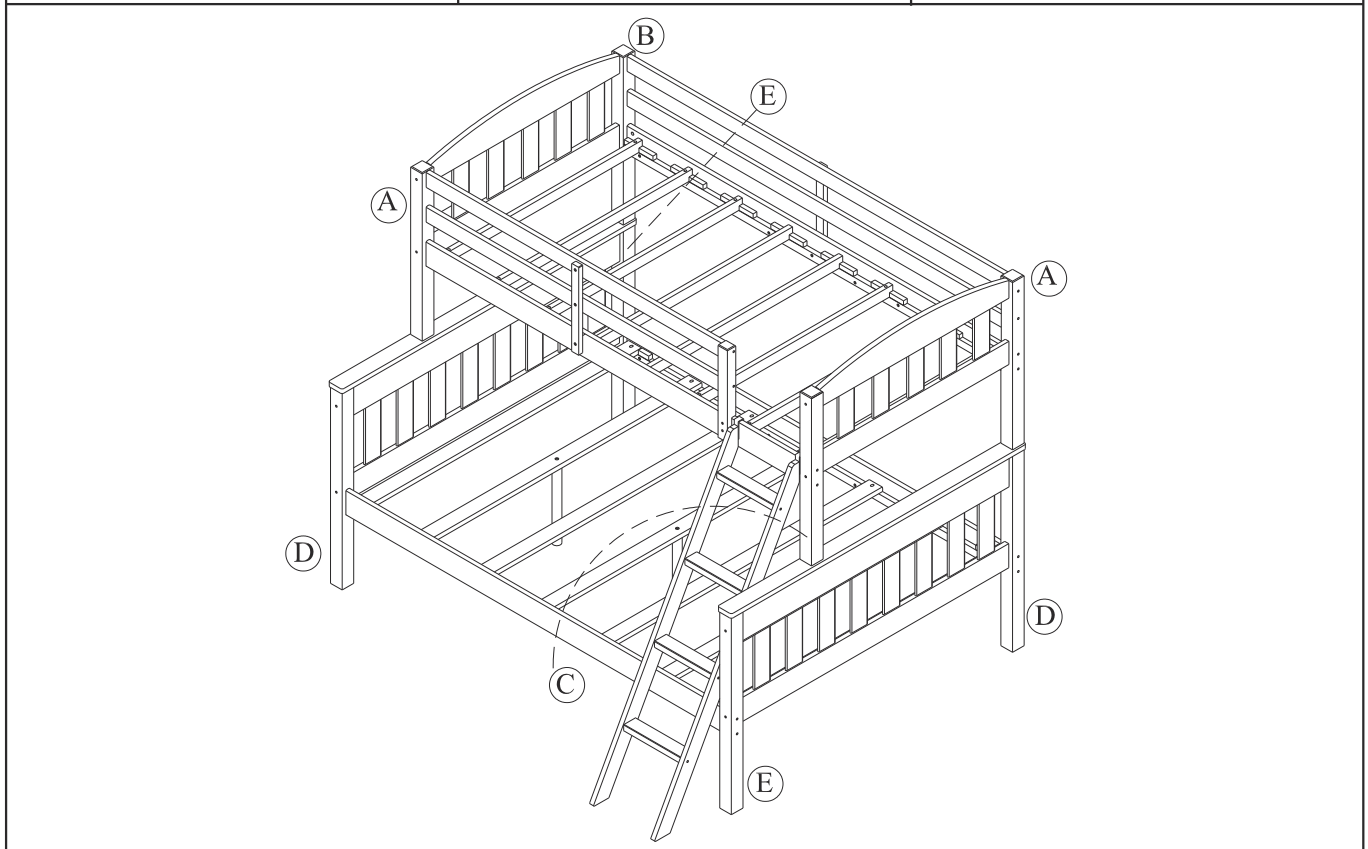
A		B		C	
	TOP POST 2 PCS		TOP POST 1 PC		TOP POST 1 PC
D		E		F	
	BOTTOM POST 2 PCS		BOTTOM POST 2 PCS		HEADBOARD TOP CROSS 2 PCS



TWIN/FULL BUNK BED

DA7499E / DA7499W / DA7499G

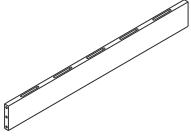
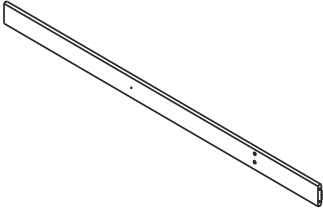
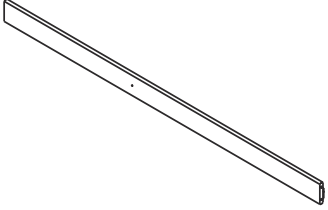
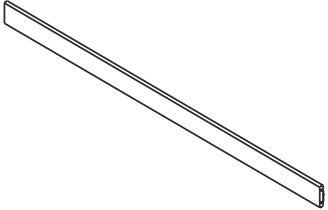
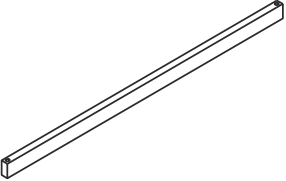
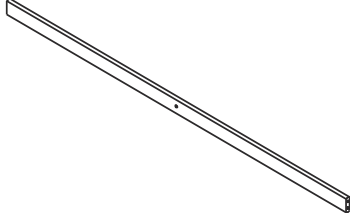
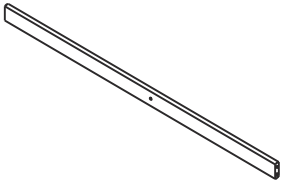
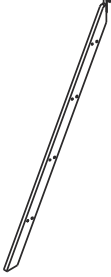
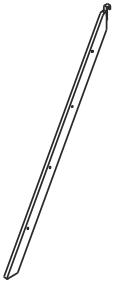
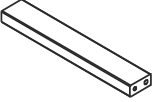





PARTS LIST

G		H		I	
HEADBOARD BOTTOM CROSS 2 PCS		TOP SIDE RAIL (WITH 3 HOLES) 1 PC		TOP SIDE RAIL (WITH 1 HOLE) 1 PC	
J		K		L	
BOTTOM SIDE RAIL 2 PCS		TOP SLAT 6 PCS		LONG GUARDRAIL 2 PCS	
M		N		O	
SHORT GUARDRAIL 2 PCS		LEFT LADDER END 1 PC		RIGHT LADDER END 1 PC	
P		Q		R	
LADDER STEP 4 PCS		GUARDRAIL LEG 2 PCS		TOP HEADBOARD SLAT 10 PCS	

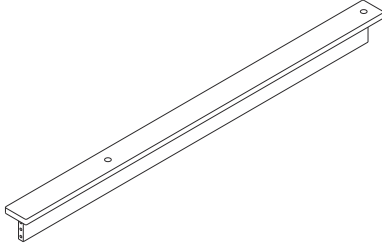
TWIN/FULL BUNK BED

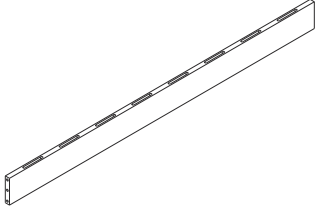
DA7499E / DA7499W / DA7499G

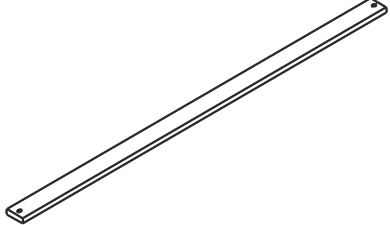
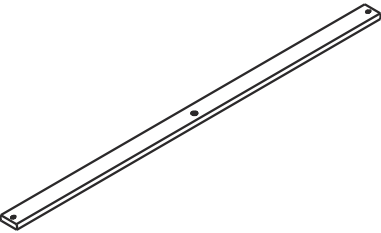
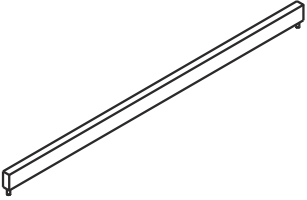
PARTS LIST

S		T		U	
SHORT GUARDRAIL POST 1 PC		BOTTOM HEADBOARD TOP CROSS 2 PCS		BOTTOM HEADBOARD SLAT 16 PCS	
V		W		X	
BOTTOM HEADBOARD TOP CROSS 2 PCS		SUPPORT POST 3 PCS		BOTTOM SLAT WITHOUT HOLE 4 PCS	
Y		Z		A1	
BOTTOM SLAT WITH 1 HOLE 3 PCS		TOP SLAT 2 PCS		SPACE BLOCK 2 PCS	

TWIN/FULL BUNK BED

DA7499E / DA7499W / DA7499G

PARTS

For replacement parts, visit www.dhpfurniture.com/spa/replacement-parts

IMPORTANT: Each part has a unique part number. Please reference the appropriate part number when contacting customer service for replacement parts.

PART NUMBERS			
PART LABELS	DA7499E (Espresso)	DA7499W (White)	DA7499G (Gray)
A	T996470	T996740	T997010
B	T996480	T996750	T997020
C	T996490	T996760	T997030
D	T996500	T996770	T997040
E	T996510	T996780	T997050
F	T996520	T996790	T997060
G	T996530	T996800	T997070
H	T996540	T996810	T997080
I	T996550	T996820	T997090
J	T996560	T996830	T997100
K	T996570	T996840	T997110
L	T996580	T996850	T997120
M	T996590	T996860	T997130
N	T996600	T996870	T997140
O	T996610	T996880	T997150
P	T996620	T996890	T997160
Q	T996630	T996900	T997170
R	T996640	T996910	T997180
S	T996650	T996920	T997190
T	T996660	T996930	T997200
U	T996670	T996940	T997210
V	T996680	T996950	T997220
W	T996690	T996960	T997230
X	T996700	T996970	T997240
Y	T996710	T996980	T997250
Z	T996720	T996990	T997260
A1	T996730	T997000	T997270

TWIN/FULL BUNK BED

DA7499E / DA7499W / DA7499G

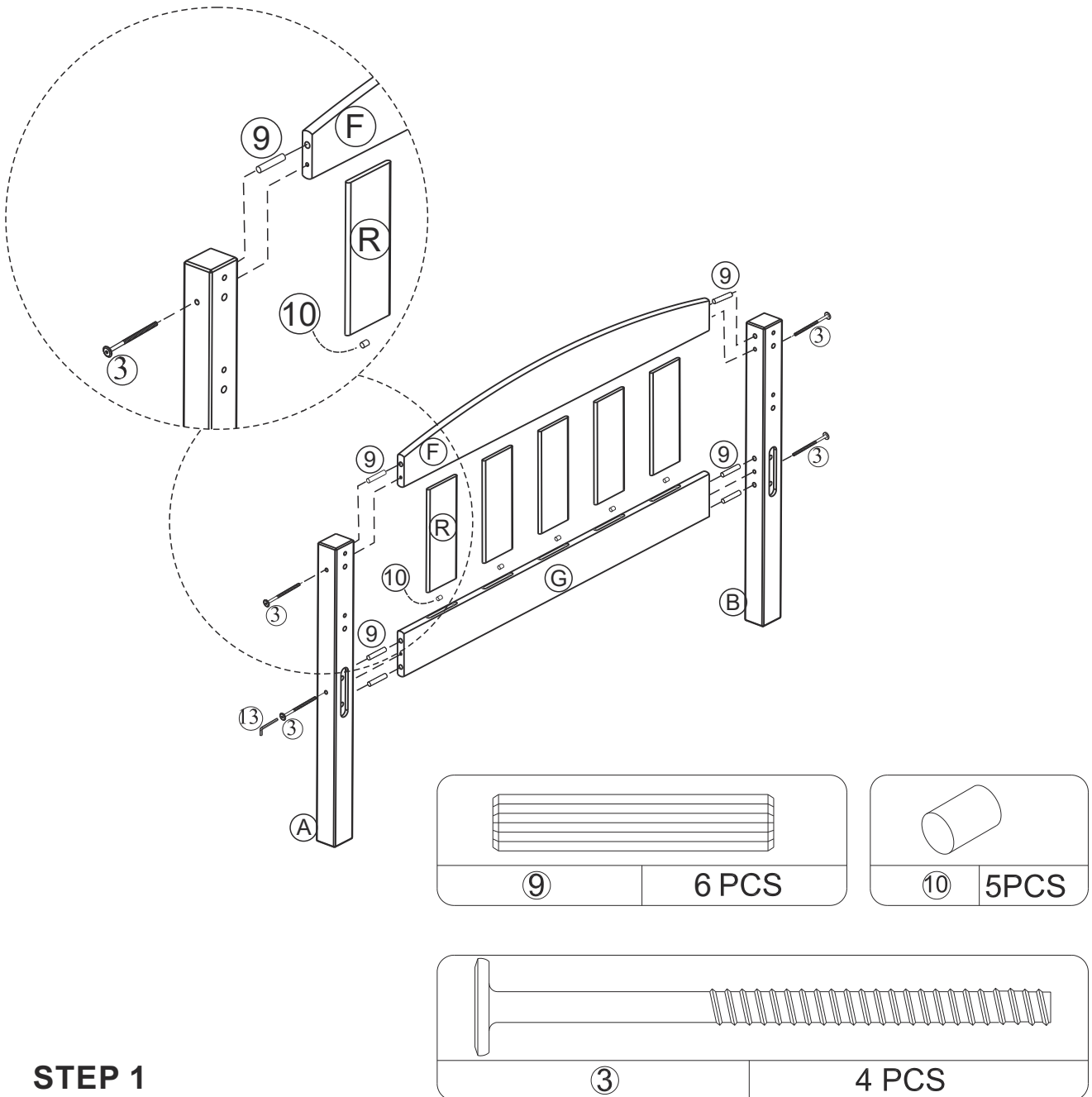

STEP 1

One of the headboard top crosses (F) has a label on it, do not use it in this step.

Insert stoppers (10) and top headboard slats (R) into each hole of the headboard bottom cross (G) and push with a downward force to secure them into place. Attach the headboard top cross (F) to the top headboard slats (R). Insert wood dowels (9) into the ends of headboard top cross (F) and headboard bottom cross (G). Attach top posts (A & B) with wood joint connectors (3). Use Allen key (13) to tighten the joint connectors as shown.

TWIN/FULL BUNK BED

DA7499E / DA7499W / DA7499G

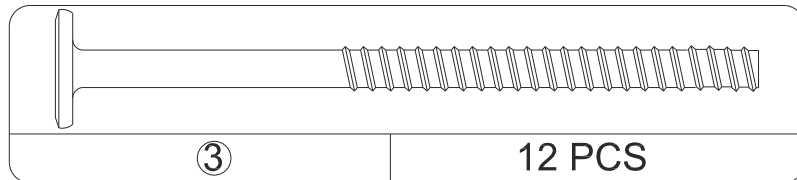
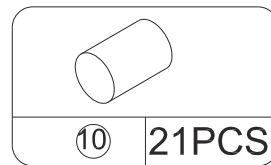
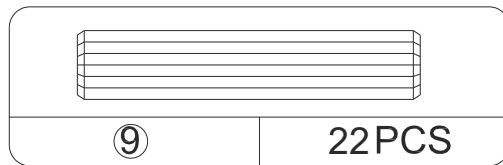
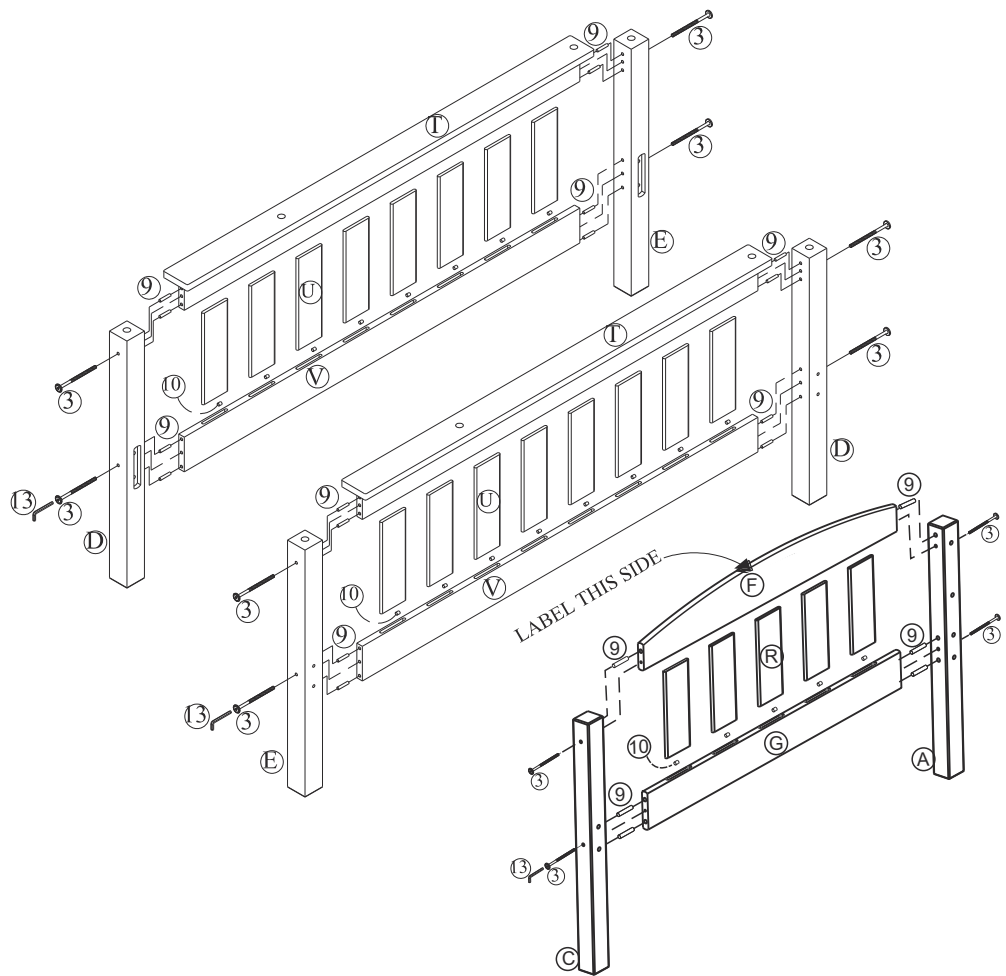

STEP 2

Repeat the previous step to assemble the remaining three sets of headboards. Be sure to pair the bottom posts (D) and (E) for one pair; (E) and (D) for another; and the top posts (C) and (A) for the last pair.

NOTE: Use headboard top cross (F) with the label attached to it between top posts (A) and (C). See illustration for label orientation.

TWIN/FULL BUNK BED

DA7499E / DA7499W / DA7499G

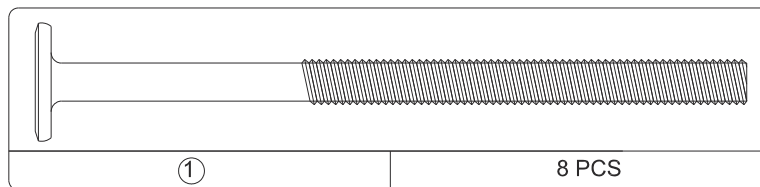
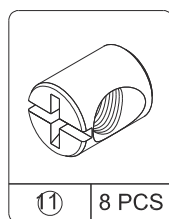
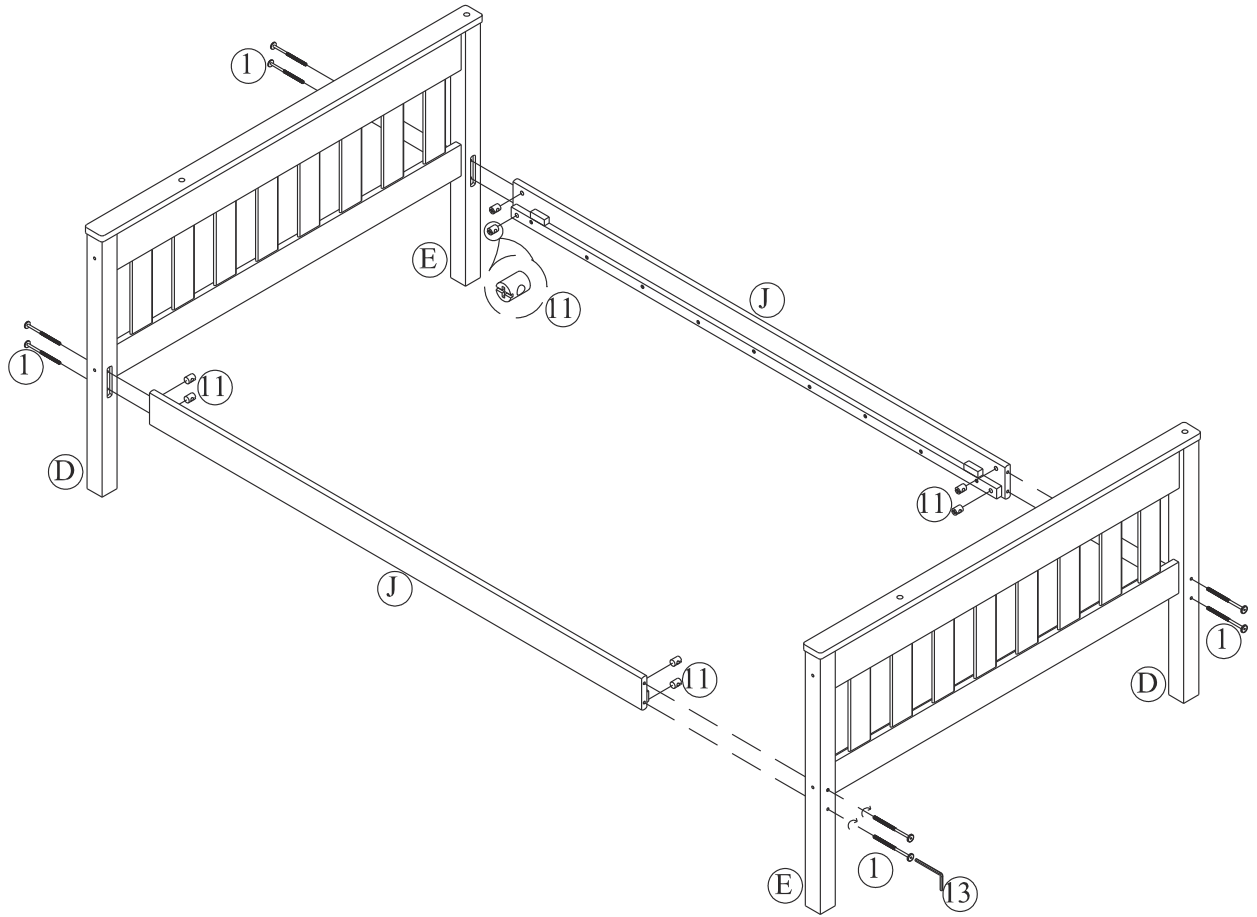

STEP 3

Insert barrel nuts (11) into the bottom side rails (J) as shown.

Attach the two headboards with bottom posts (D & E) to bottom side rails (J) with joint connectors (1) and Allen key (13).

Note: This is the lower bunk.

TWIN/FULL BUNK BED

DA7499E / DA7499W / DA7499G

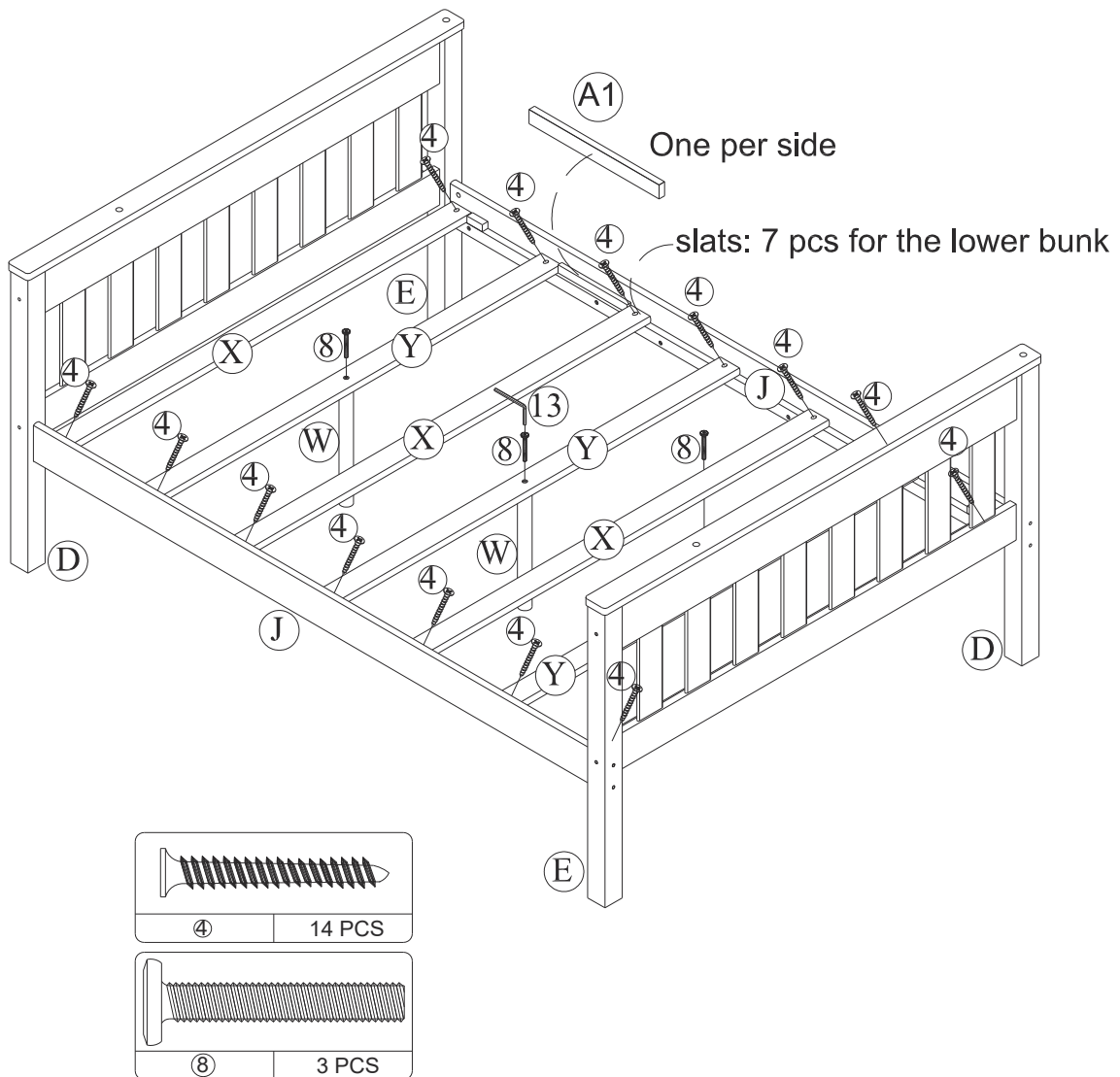

STEP 4

Attach the support posts (W) to bottom slats (Y) of the bottom bunk with hex socket head bolts (8) as shown.

Attach a bottom slat (X) to bottom side rails (J) with flat head wood screws (4). Make sure the slat touches the corner posts (as close to the headboard as possible).

Attach the other slats (X & Y) to the bottom side rails (J) with flat head wood screws (4) using a Phillips head screw driver (not included). Use space block (A1) to space them out evenly as shown.

NOTE: If you notice that any of the slats (X & Y) are not perfectly flat, make sure to assemble them so that the slats (X & Y) curves up in the middle and down on the ends.

TWIN/FULL BUNK BED

DA7499E / DA7499W / DA7499G

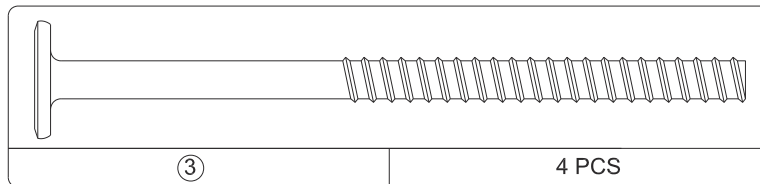
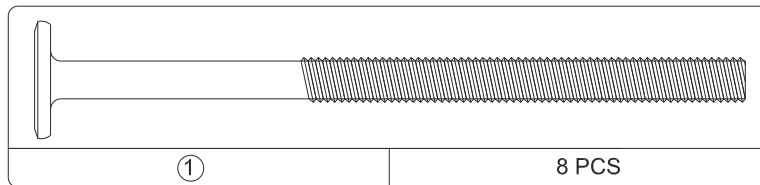
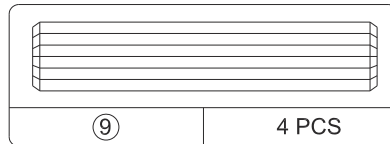
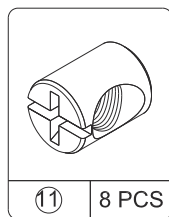
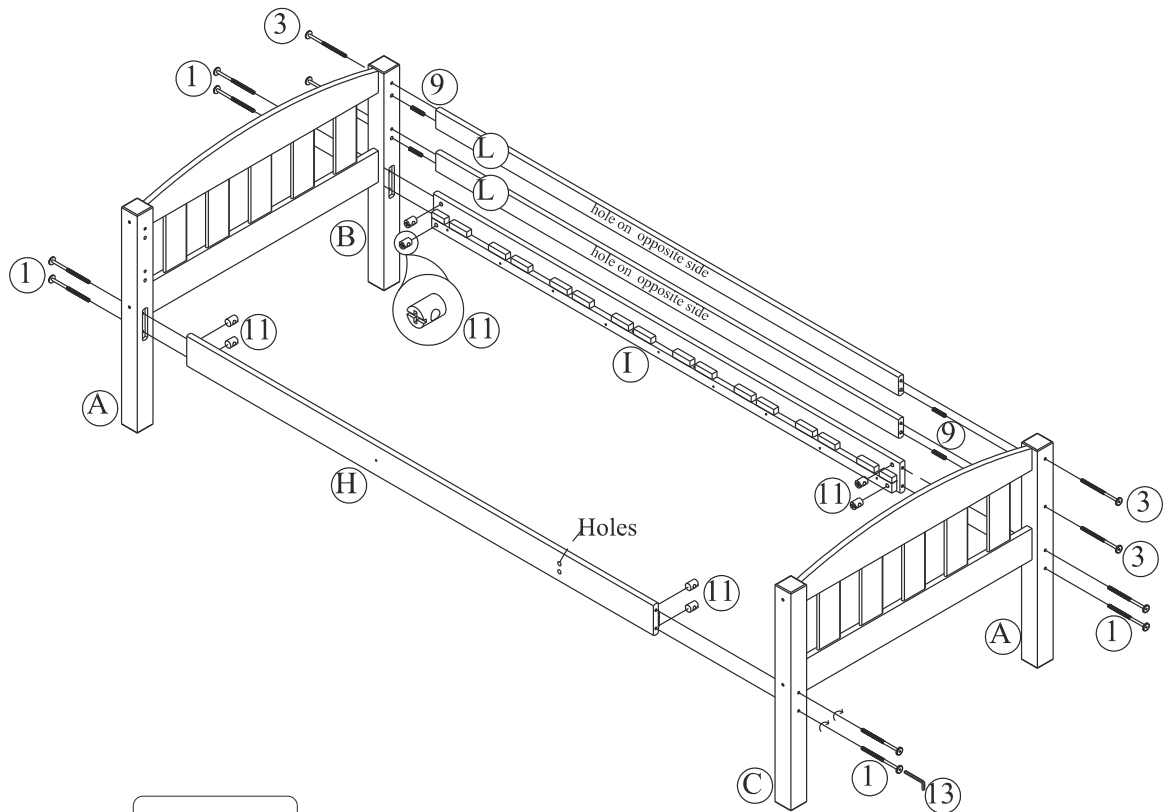

STEP 5

Insert wood dowels (9) into each end of the long guardrails (L).
 Insert barrel nuts (11) into the side rails (H & I).
 Attach two long guardrails (L) and two top side rails (H & I) to the top posts (A & B) and (A & C) with wood joint connectors (1) & (3).
 Use Allen key (13) to tighten all joint connectors.
 This is the upper bunk.

TWIN/FULL BUNK BED

DA7499E / DA7499W / DA7499G

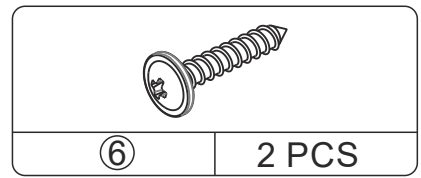
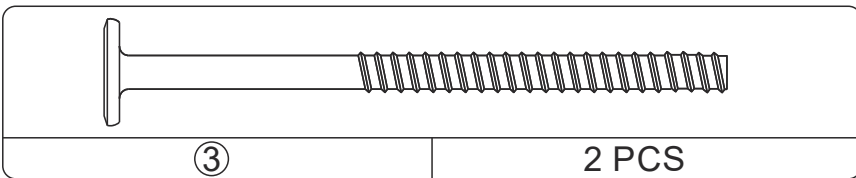
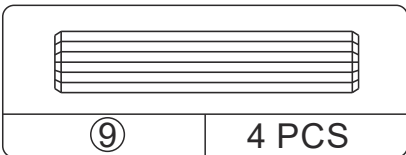
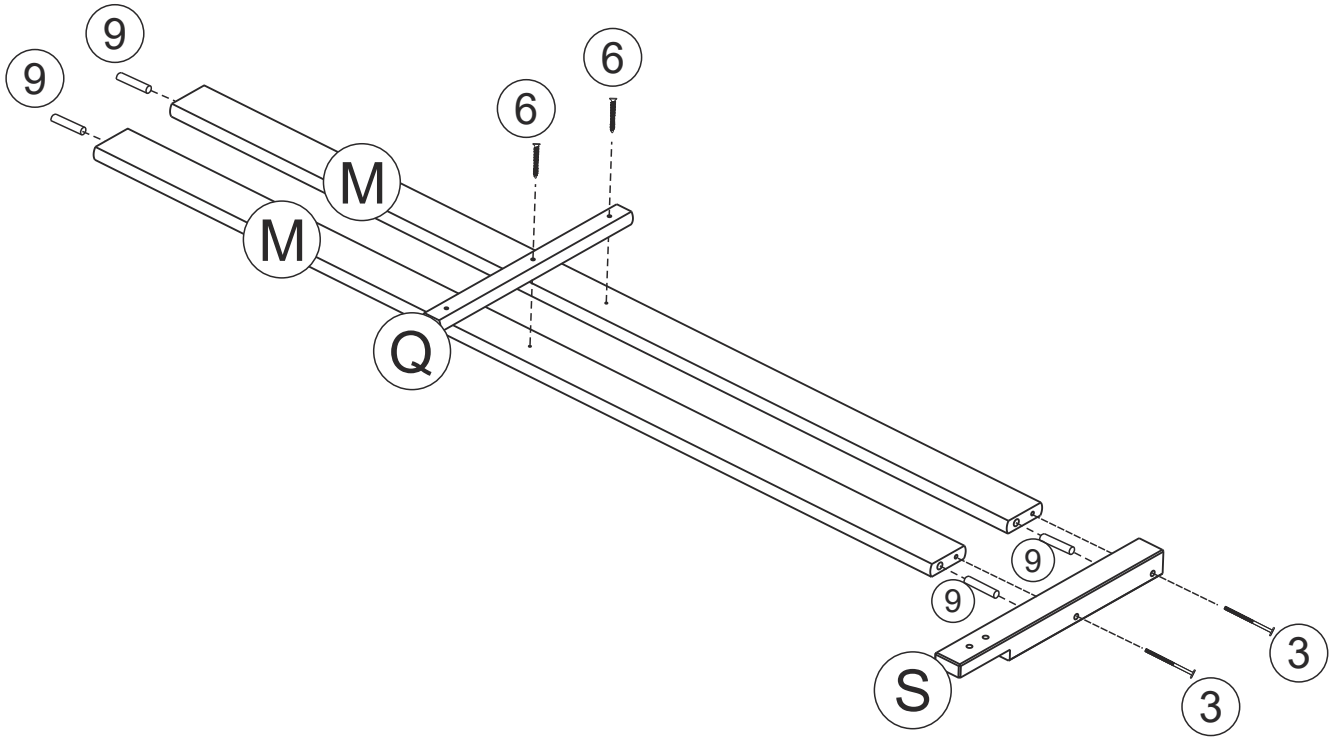

STEP 6

Insert the dowels (9) into each end of short guardrails (M). Attach the short guardrail post (S) and one guardrail leg (Q) to the short guardrails (M) with wood joint connectors (3) and flat head wood screws (6).

TWIN/FULL BUNK BED

DA7499E / DA7499W / DA7499G

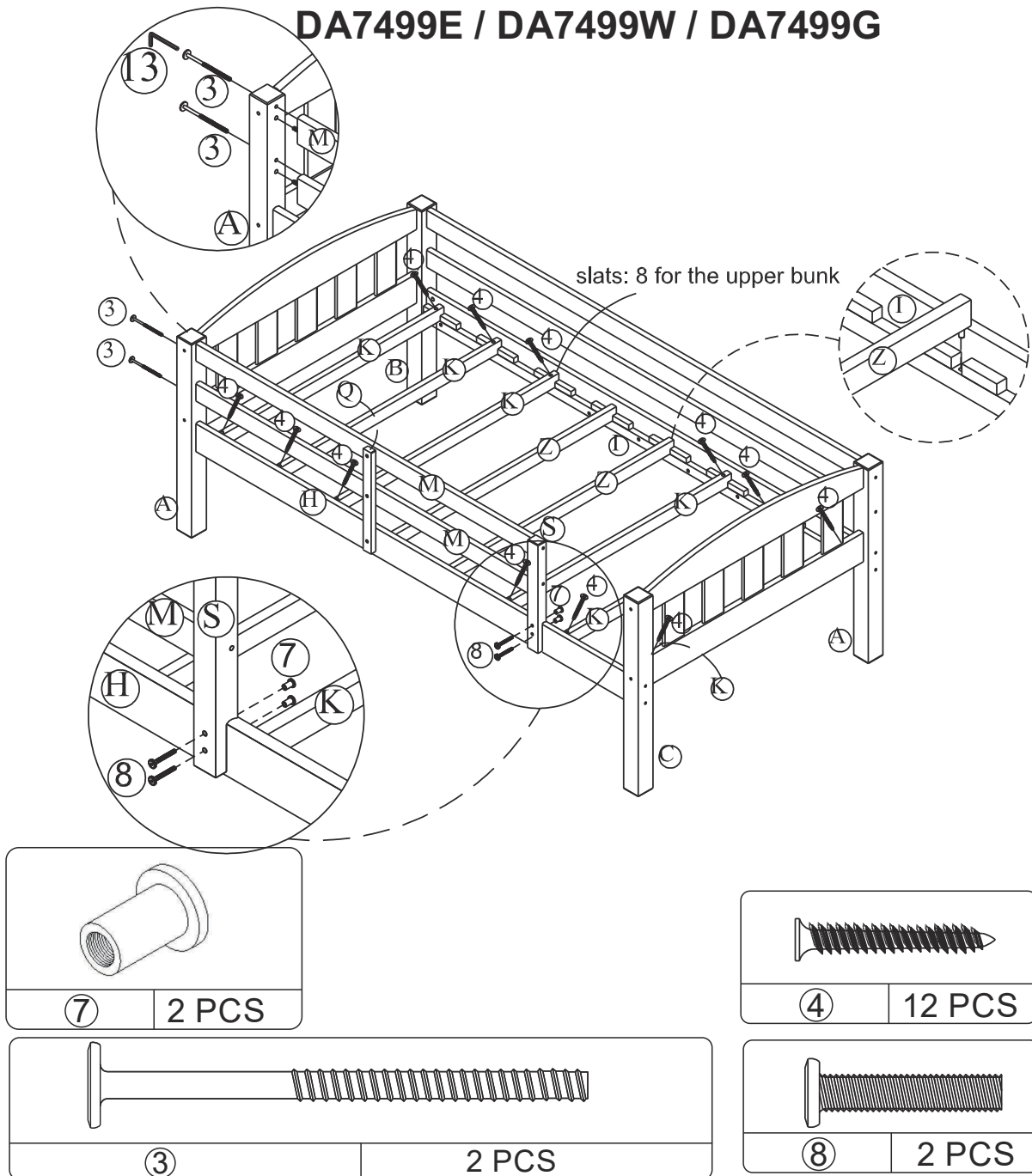

STEP 7

Attach assembled short guardrail to the top post (A) with wood joint connectors (3), and to the top side rail (H) with hex socket head bolts (8) and hex caps (7) as shown. Use Allen key (13) to tighten the hex caps (7).

Attach a top slat (K) into the top side rails (H & I) of the top bunk with flat head wood screws (4). Make sure the slat touches the corner posts (as close to the headboard as possible). Attach the other slats (K) into the top side rails (H & I) with flat head wood screws (4) and place the slats (Z) into the top side rails (H & I) as shown.

NOTE: Slats (K & Z) must be attached so that they curve up in the middle and down on the ends.

TWIN/FULL BUNK BED

DA7499E / DA7499W / DA7499G

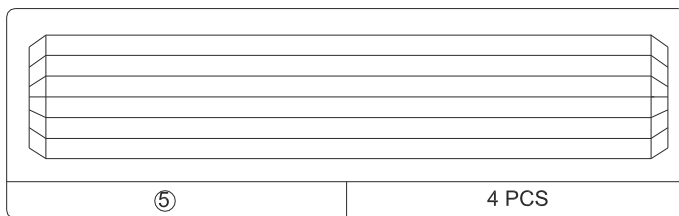
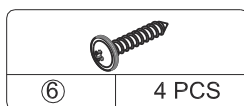
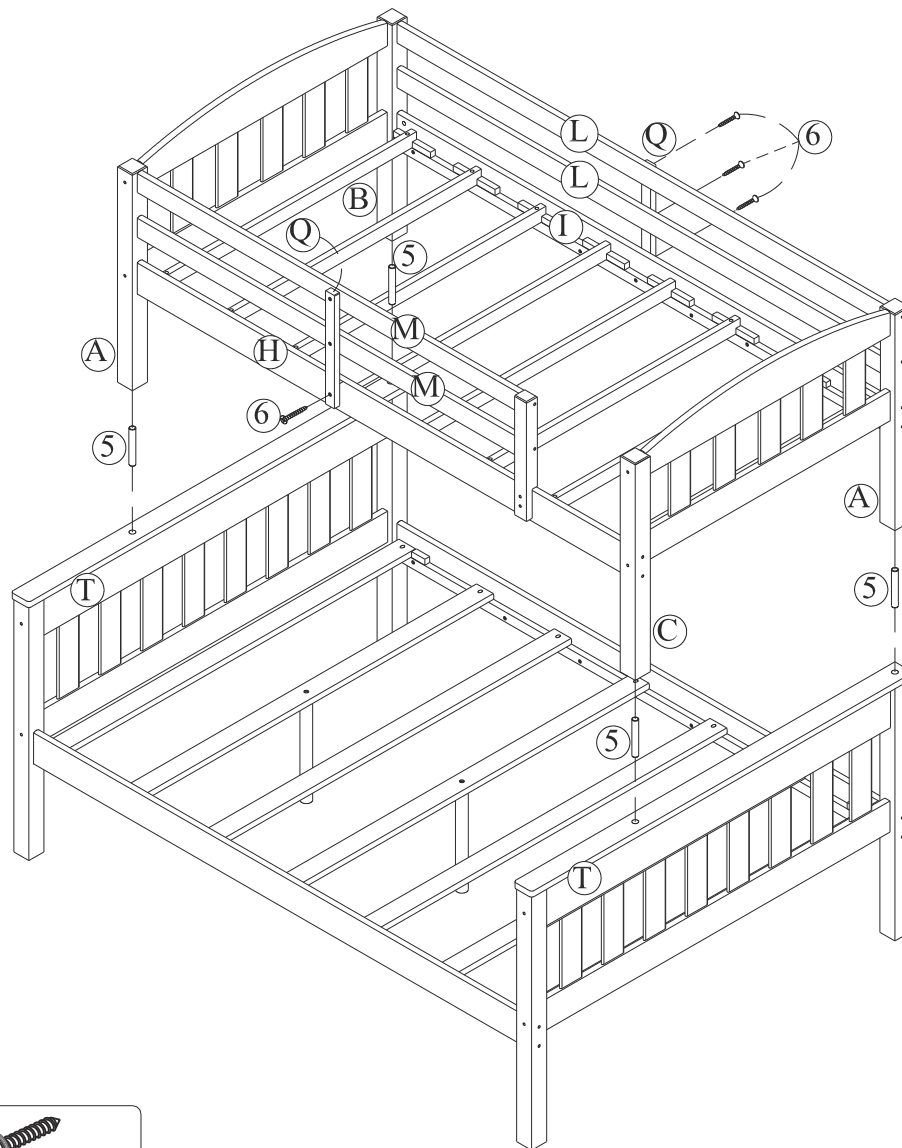

STEP 8

Attach the other guardrail leg (Q) to long guardrails (L) and top side rail (I) with flat head wood screws (6).

Secure the guardrail leg (Q) (done in step 6) to the top side rail (H) with flat head wood screw (6) as shown.

Place four wood dowels (5) into the holes in the bottom headboard top crosses (T). With the help of another person, stack the top bunk onto the bottom bunk.

TWIN/FULL BUNK BED

DA7499E / DA7499W / DA7499G

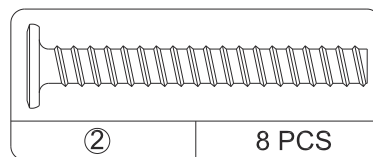
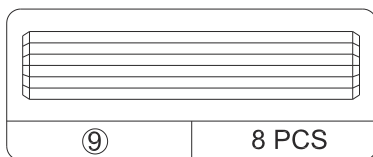
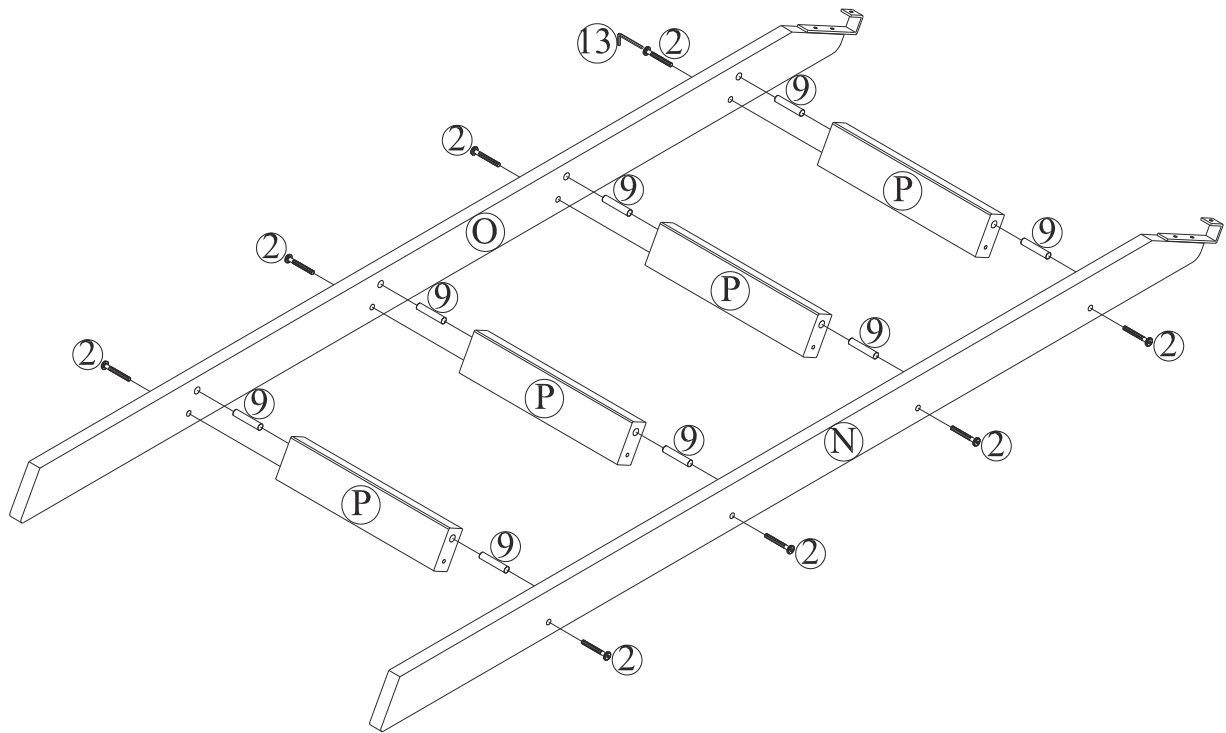

STEP 9

Insert wood dowels (9) into the ends of the ladder steps (P). Attach left ladder end (N) and right ladder end (O) to ladder steps (P) with wood joint connectors (2). Use Allen key (13) to tighten the joint connectors as shown.

TWIN/FULL BUNK BED

DA7499E / DA7499W / DA7499G

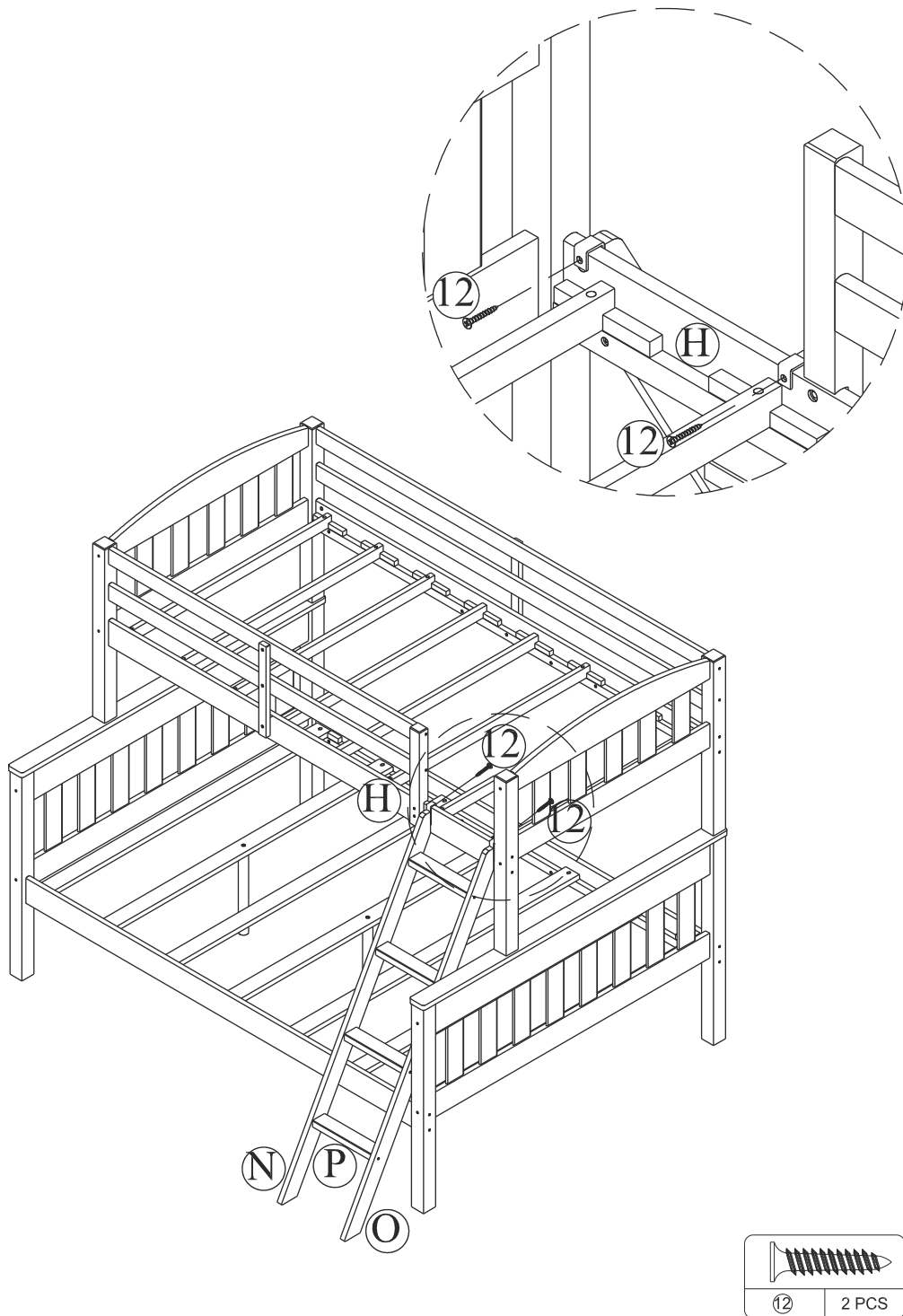

STEP 10

Attach the ladder to the top side rail (H) with flat head screw (12) as shown.

TWIN/FULL BUNK BED

DA7499E / DA7499W / DA7499G

Instructions for converting the bunk bed into two single beds

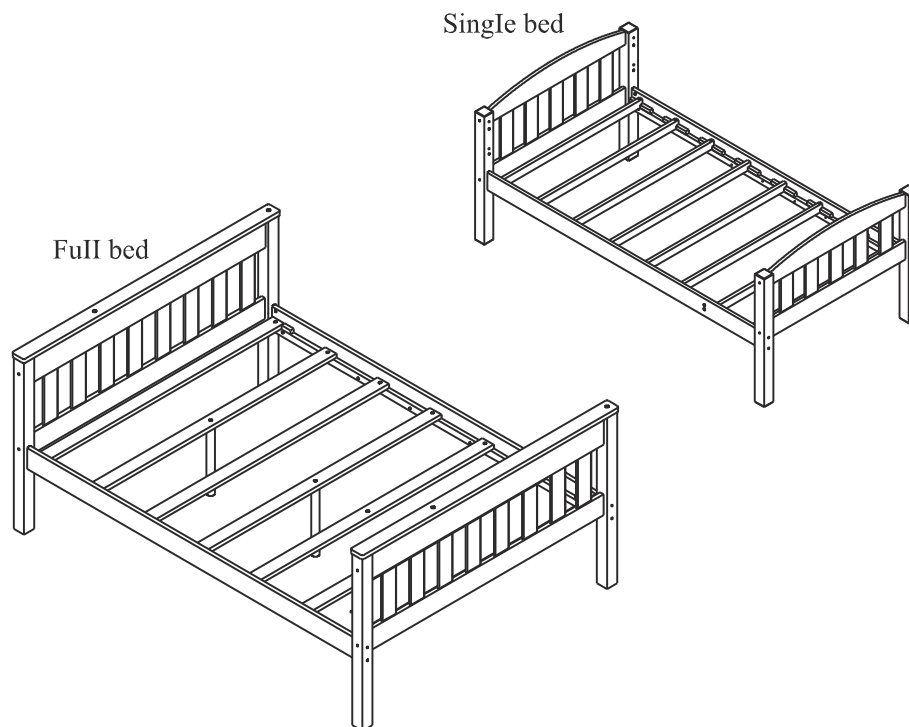
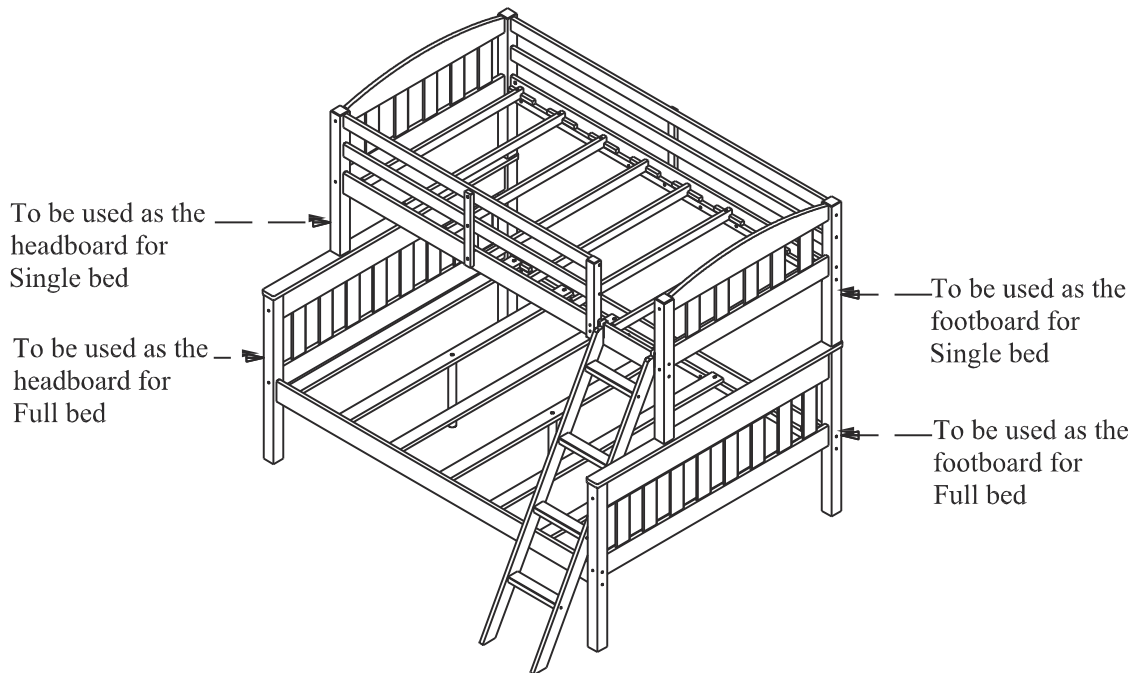

CONVERTING THE BUNK BED INTO A FULL BED AND A TWIN BED

Remove the ladder and all the guardrails.

With the help of another person, detach the top bunk from the lower bunk and remove the wood dowels from the posts.

TWIN/FULL BUNK BED

DA7499E / DA7499W / DA7499G

! CAUTION: This unit is intended for use only with the products and/or maximum weights indicated. Use with other products and/or products heavier than the maximum weights indicated may result in instability or cause possible injury.

DO NOT ALLOW HORSEPLAY ON OR UNDER THE BED AND PROHIBIT JUMPING ON THE BED.

DO NOT ALLOW CHILDREN UNDER 6 YEARS OF AGE TO USE THE UPPER BUNK. BED IS DESIGNED FOR CHILDREN RANGING FROM 6 YEARS OF AGE TO YOUNG TEENAGERS.

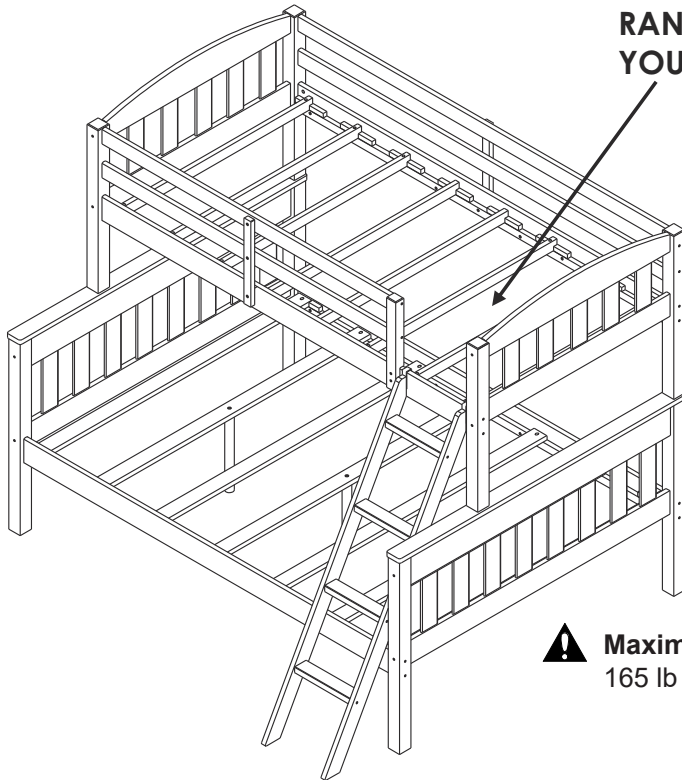

USE ONLY COIL SPRING MATTRESSES ON BOTH THE UPPER AND LOWER BUNKS. FAILURE TO DO SO CAN RESULT IN INJURY.

! Maximum Weight :
165 lb / 75 kg Per level

USE ONLY MATTRESSES WHICH ARE 74"-75" LONG AND 37 1/2" - 38 1/2" WIDE ON UPPER BED AND AT LEAST 74"-75" LONG AND 53"-54" WIDE ON LOWER BED. ENSURE THICKNESS OF MATTRESS DOES NOT EXCEED 6".

That's it! You've finished assembling your bunk bed.

DO NOT RETURN PRODUCT TO THE STORE.

If a part is missing or damaged, contact our customer service department. We will replace the part **FREE** of charge.

Tel #: 1-800-267-1739

E-Mail: cs@dhpffurniture.com

CAMA LITERA SIMPLE/DOBLE

Modelo No:	CODIGO UPC:	Color:
DA7499E	0-65857-17298-0	Expreso
DA7499W	0-65857-17299-7	Blanco
DA7499G	0-65857-17755-8	Gris

¡Felicitaciones por su nueva compra de un mueble! Los muebles de la línea **Dorel Living** han sido diseñados con la calidad, la comodidad y el estilo en mente. Estamos seguros de que este mueble le servirá por muchos años con su comodidad excepcional.

Le recomendamos que antes de comenzar a armarlo se familiarice con su nueva compra y tome unos minutos de su tiempo para leer este manual. Contiene información importante sobre nuestra garantía y consejos de cuidados para que su mueble siempre conserve su apariencia de nuevo.

Para obtener más ideas de muebles inspirantes, visite nuestro sitio web en www.dorelliving.com

También puede mantenerse informado de todas las últimas tendencias suscribiéndose a nuestra página en [Facebook](#) y [Instagram](#).

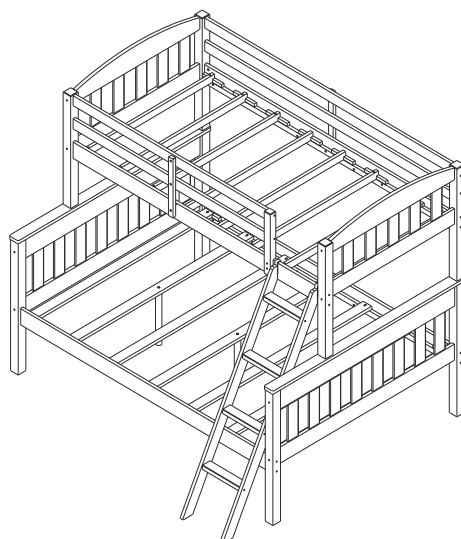

▲ Límites de peso:
165 Lb / 75 kg Por nivel

Fecha de compra: ____ / ____ / ____

Número de lote: _____
(tomado del cartón)

Número del Manual de Instrucciones : B34DA7499001 - 136832

Preguntas, inquietudes, partes que faltan? La satisfacción del cliente es importante para nosotros en Dorel Asia. **CONTACTE NUESTRO DEPARTAMENTO DE SERVICIO AL CLIENTE ANTES DE DEVOLVER EL PRODUCTO A LA TIENDA.**

cs@dhpffurniture.com

1-800-267-1739

Lunes - Viernes 9:00 am to 9:00 pm (hora del este)

Sábado 10 am to 6:30 pm (hora del este)

Domingo 11 am to 7 pm (hora del este)

DHP Consumer Services

12345 Albert-Hudon Boulevard, Suite 100

Montreal, Québec, Canada, H1G 3L1

NOTA: ESTE MANUAL DE INSTRUCCIONES CONTIENE INFORMACIÓN DE SEGURIDAD IMPORTANTE. POR FAVOR, LÉALO Y CONSÉRVELO PARA CONSULTARLO EN EL FUTURO.

SERVICIO AL CLIENTE

También puede contactarnos escribiendo a la dirección que figura a continuación. Por favor incluya el número de modelo del producto, el color y una descripción detallada de su pregunta.

DHP Consumer Services
12345 Albert-Hudon Boulevard, Suite 100
Montreal, Quebec
Canada, H1G 3L1

NOTAS E INSTALACIÓN

- LEA ATENTAMENTE CADA ETAPA ANTES DE COMENZAR. ES MUY IMPORTANTE QUE CADA ETAPA SE LLEVE A CABO EN EL ORDEN CORRECTO. SI ESTAS ETAPAS NO SE SIGUEN EN ORDEN, PUEDEN SURGIR DIFICULTADES PARA ARMAR LA CAMA Y CAUSAR LESIONES A LOS NIÑOS QUE LA USAN.
- DEBE SER ARMADA POR UN ADULTO.
- ASEGÚRESE DE TENER TODAS LAS PIEZAS. TRABAJE EN UN LUGAR ESPACIOSO, DE PREFERENCIA SOBRE UN TAPIZ.
- SE NECESITARÁN DOS PERSONAS PARA ARMARLA.
- LA MAYORÍA DE LAS PIEZAS DE MADERA ESTÁN ETIQUETADAS O MARCADAS DEL LADO RÚSTICO.
- SE NECESITA UN DESTORNILLADOR EN CRUZ (NO INCLUIDO).
- SE RECOMIENDA EL USO DE UNA MAZA DE CAUCHO (NO INCLUIDA) PARA FACILITAR EL TRABAJO.
- LA CAMA ESTÁ DISEÑADA PARA NIÑOS DESDE 6 AÑOS HASTA LA ADOLESCENCIA TEMPRANA.

CUIDADO, LIMPIEZA Y MANTENIMIENTO

Limpie el polvo regularmente con un paño suave y seco. Se recomienda no usar productos químicos o cera en nuestros muebles laqueados, ya que se puede dañar el pulido.

Mantenga solventes, alcohol, esmalte de uñas y quita-esmaltes lejos de toda superficie de madera de los muebles.

Verifique los pernos y tornillos periódicamente y ajústelos si es necesario.

GARANTÍA LIMITADA DE 1 AÑO

Dorel garantiza que este producto está libre de defectos de material y mano de obra y se compromete a remediar cualquier defecto de este tipo. Esta garantía cubre 1 año a partir de la fecha de compra original. Esta garantía es válida solamente con presentación de una prueba de compra. Esto se limita a la reparación o reemplazo de componentes defectuosos del mueble y no se incluye ningún trabajo de ensamblaje. Esta garantía no se aplica a ningún producto que haya sido mal ensamblado, sujeto a mal uso o abuso, o que haya sido alterado o reparado de cualquier manera. Cualquier uso, rotura o pérdida de color de la tela no están incluidos en esta garantía (donde corresponda). Esta garantía le da derechos legales específicas y usted puede también tener otros derechos que varían de estado a estado o de provincia a provincia.



ADVERTENCIA: Si este producto está dañado y/o ciertas piezas faltan o están rotas, NO LO USE.





PRECAUCIÓN - Litera : Individual / Matrimonial

- **PELIGRO DE ESTRANGULAMIENTO** - Nunca cuelgue o ate en la cama artículos que no estén diseñados para usarlos con la cama; por ejemplo, pero no limitado a esto, ganchos, cinturones y cuerdas de saltar.
- Siga la información de las advertencias inscritas en la estructura de la cucheta superior y en el cartón. No retire la etiqueta de advertencias de la cama.
- La base del colchón está diseñada para soportar un colchón sin necesidad de usar una tabla para mantener la posición o un soporte con resortes.
- Siempre utilice el tamaño de colchón o de soporte de colchón recomendado, o los dos, para evitar la posibilidad de caídas o que el niño quede atrapado.
- **UTILICE SOLAMENTE COLCHONES CON RESORTES EN ESPIRAL EN LAS DOS CUCHETAS. EL NO RESPETAR ESTO PUEDE CAUSAR LESIONES.**
- Utilice únicamente colchones de **74"-75"** de largo y **37 1/2" - 38 1/2"** de ancho en la litera superior y por lo menos **74"-75"** de largo y **53"-54"** de ancho en la litera inferior. Asegúrese de que el espesor del colchón no exceda **15 cm (6")**. La superficie del colchón debe quedar por lo menos **5" (127 mm)** por debajo del borde superior del marco de las cuchetas.
- No permita que niños menores de **6** años duerman en la cucheta superior.
- Siempre utilice las barandas en los dos lados de la cucheta superior. Si la cucheta está colocada al lado de una pared, la baranda que cubre el lado largo de la cucheta debe ser colocada contra la pared para evitar que el niño quede atrapado entre la cama y la pared (esto se aplica a las cuchetas con baranda larga de un solo lado).
- Verifique la cama periódicamente y asegúrese de que el cuadro, la escalerilla y otros componentes estén en la posición correcta, no estén dañados y todas las uniones estén bien ajustadas.
- No permita que los niños hagan payasadas sobre o debajo de la cama y prohíba que salten sobre ella.
- No utilice piezas de sustitución. Contacte con el fabricante o el distribuidor para obtener piezas para reemplazar.
- El uso de una veladora sirve como medida de precaución para el niño que utiliza la cucheta superior.
- Se prohíbe el uso de colchones de agua o colchonetas de flotación.
- Siempre utilice la escalerilla para subir a la cucheta superior o bajar de ella.
- Prohíba que más de un niño suba a la cucheta superior.
- Conserve estas instrucciones para referencia futura.

CAMA LITERA SIMPLE/DOBLE

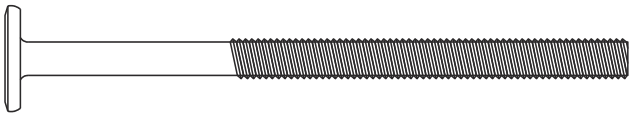
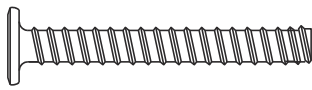
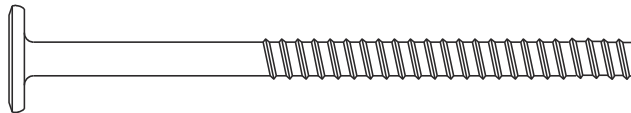
DA7499E / DA7499W / DA7499G

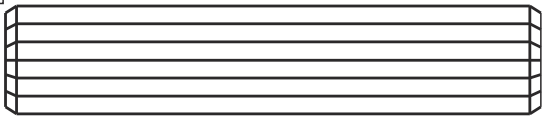
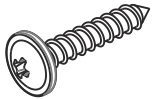
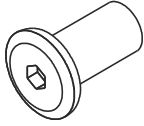
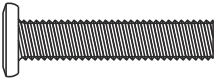
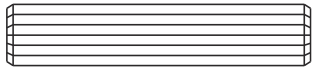
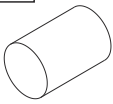
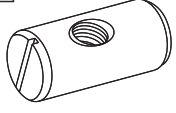
LISTA DE TORNILLOS Y ACCESORIOS

<p style="text-align: center;">1</p>  <p style="text-align: center;">$\varnothing 1/4" \times 100\text{mm}$</p> <p style="text-align: center;">PERNOS CONECTORES 16 PZAS</p>	<p style="text-align: center;">2</p>  <p style="text-align: center;">$\varnothing 6.5\text{mm} \times 48\text{mm}$</p> <p style="text-align: center;">PERNOS CONECTORES MADERA 8 PZA</p>		
<p style="text-align: center;">3</p>  <p style="text-align: center;">$\varnothing 6.5\text{mm} \times 100\text{mm}$</p> <p style="text-align: center;">PERNOS CONECTORES MADERA 24 PZAS</p>	<p style="text-align: center;">4</p>  <p style="text-align: center;">$\varnothing 4\text{mm} \times 35\text{mm}$</p> <p style="text-align: center;">TORNILLOS MADERA CABEZA PLANA 26 PZAS</p>		
<p style="text-align: center;">5</p>  <p style="text-align: center;">$\varnothing 15\text{mm} \times 100\text{mm}$</p> <p style="text-align: center;">TARUGOS DE MADERA 4 PZAS</p>	<p style="text-align: center;">6</p>  <p style="text-align: center;">$4\text{mm} \times 35\text{mm}$</p> <p style="text-align: center;">TORNILLOS MADERA CABEZA FLANG 6 PZAS</p>		
<p style="text-align: center;">7</p>  <p style="text-align: center;">$\varnothing 9\text{mm} \times 17\text{mm}$</p> <p style="text-align: center;">TORNILLOS DE CASQUETE CABEZA HEXAGONAL 2 PZAS</p>	<p style="text-align: center;">8</p>  <p style="text-align: center;">$\varnothing 1/4" \times 32\text{mm}$</p> <p style="text-align: center;">PERNOS DE CABEZA HEXAGONAL 5 PZAS</p>	<p style="text-align: center;">9</p>  <p style="text-align: center;">$\varnothing 10\text{mm} \times 50\text{mm}$</p> <p style="text-align: center;">TARUGOS DE MADERA 44 PZAS</p>	<p style="text-align: center;">10</p>  <p style="text-align: center;">TOPE 26 PZAS</p>
<p style="text-align: center;">11</p>  <p style="text-align: center;">$\varnothing 11.8\text{mm} \times 15\text{mm}$</p> <p style="text-align: center;">TUERCAS BARRILETE 16 PZAS</p>	<p style="text-align: center;">12</p>  <p style="text-align: center;">$\varnothing 4\text{mm} \times 19\text{mm}$</p> <p style="text-align: center;">TORNILLOS CABEZA PLANA 2 PZAS</p>	<p style="text-align: center;">13</p>  <p style="text-align: center;">LLAVE ALLEN 1 PZA</p>	

CAMA LITERA SIMPLE/DOBLE

DA7499E / DA7499W / DA7499G

Paquete de componentes

de Paquete :

DA7499E (Expreso) DA7499G (Gris)	# de Paquete : <input checked="" type="checkbox"/> TDA7499E-00
DA7499W (Blanco)	# de Paquete : <input type="checkbox"/> TDA7499W-00



Nota: Por favor no apriete completamente los pernos hasta que el ensamblaje sea completado, a menos de que se indique específicamente en cada paso de las instrucciones.







Los tornillo(s), perno(s) que se utilizan en cada paso se muestran en tamaño real en la esquina inferior derecha de cada página.

CAMA LITERA SIMPLE/DOBLE

DA7499E / DA7499W / DA7499G

LISTA DE PIEZAS

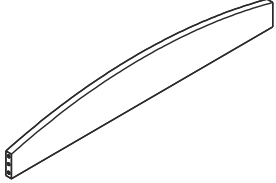

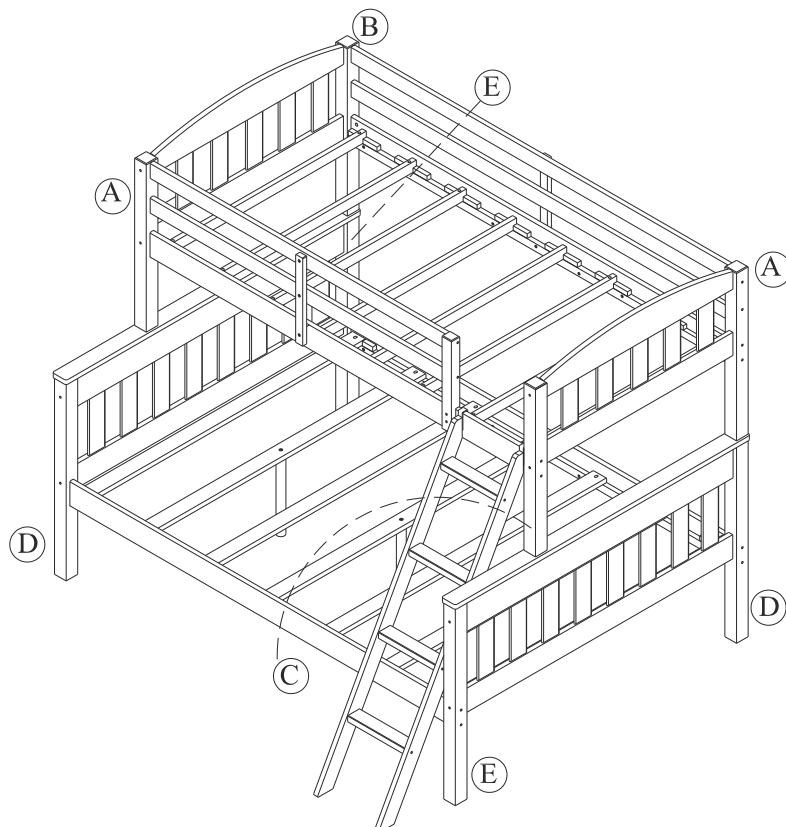

A 	B 	C 
PATA SUPERIOR 2 PZAS	PATA SUPERIOR 1 PZA	PATA SUPERIOR 1 PZA
D 	E 	F 
PATA INFERIOR- 2 PZAS	PATA INFERIOR- 2 PZAS	TRAVESAÑO SUPERIOR CABECERA 2 PZAS

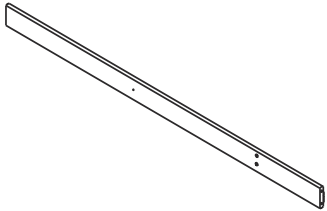
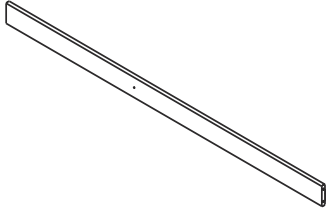
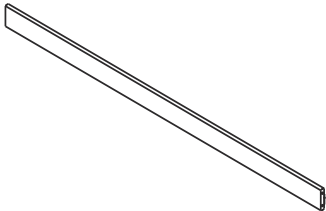
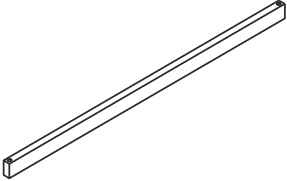
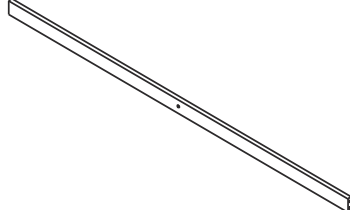
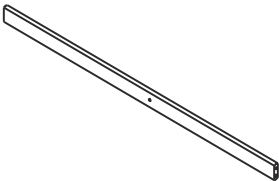
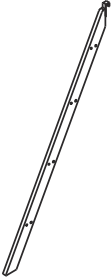
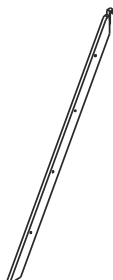

CAMA LITERA SIMPLE/DOBLE

DA7499E / DA7499W / DA7499G







LISTA DE PIEZAS

<p>G</p> 	<p>H</p> 	<p>I</p> 
<p>TRAVESAÑO INFERIOR CABECERA 2 PZAS</p>	<p>LARGUERO LATERAL SUPERIOR (CON 3 AGUJEROS) 1 PZA</p>	<p>LARGUERO LATERAL SUPERIOR (CON 1 AGUJERO) 1 PZA</p>
<p>J</p> 	<p>K</p> 	<p>L</p> 
<p>LARGUERO LATERAL INFERIOR 2 PZAS</p>	<p>LISTONES SUPERIOR 6 PZAS</p>	<p>LARGUERO LARGO DE BARANDILLA 2 PZAS</p>
<p>M</p> 	<p>N</p> 	<p>O</p> 
<p>LARGUERO CORTO DE BARANDILLA</p>	<p>LADO IZQUIERDO ESCALERA 1 PZA</p>	<p>LADO DERECHO ESCALERA 1 PZA</p>
<p>P</p> 	<p>Q</p> 	<p>R</p> 
<p>ESCALONES 4 PZAS</p>	<p>PATA DE BARANDILLA 2 PZAS</p>	<p>LISTÓN CABECERA SUPERIOR</p>

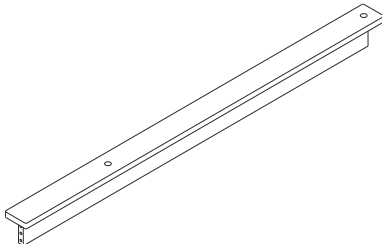
CAMA LITERA SIMPLE/DOBLE

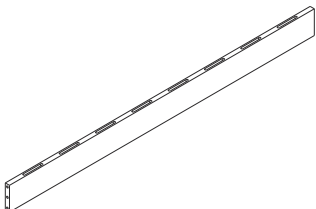
DA7499E / DA7499W / DA7499G

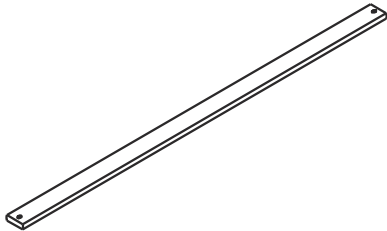
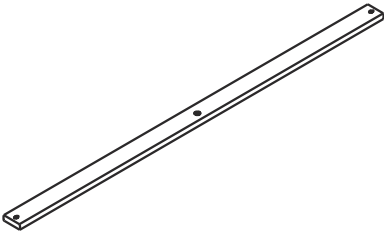
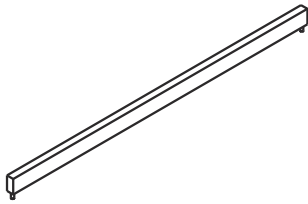
LISTA DE PIEZAS

<p>S</p> 	<p>T</p> 	<p>U</p> 
<p>PATA CORTA BARANDILLA 1 PZA</p>	<p>TRAVESAÑO SUPERIOR DE CABECERA INFERIOR 2 PZAS</p>	<p>LISTÓN CABECERA INFERIOR 16 PZAS</p>
<p>V</p> 	<p>W</p> 	<p>X</p> 
<p>TRAVESAÑO SUPERIOR DE CABECERA INFERIOR 2 PZAS</p>	<p>PATA DE APOYO 3 PZAS</p>	<p>LISTON INFERIOR (SIN AGUJERO) 4 PZAS</p>
<p>Y</p> 	<p>Z</p> 	<p>A1</p> 
<p>LISTON INFERIOR (CON 1 AGUJERO) 3 PZAS</p>	<p>LISTON SUPERIOR 2 PZAS</p>	<p>SEPARADOR 2 PZAS</p>

CAMA LITERA SIMPLE/DOBLE

DA7499E / DA7499W / DA7499G

Partes

Piezas de reemplazo, visite www.dhpfurniture.com/spa/replacement-parts

IMPORTANTE: La lista de números de piezas que aparece a continuación es exclusiva de su producto. Por favor, manténgalo a mano cuando solicite piezas de repuesto.



Antes de deshacerse de las cajas de cartón, asegúrese de que estén vacías. También confirme que ha recibido todos los componentes necesarios para el ensamblaje al compararlos con la tabla de piezas indicadas en la sección en inglés.

NÚMERO DE PIEZAS			
ETIQUETAS DE PIEZAS	DA7499E (Expreso)	DA7499W (Blanco)	DA7499G (Gris)
A	T996470	T996740	T997010
B	T996480	T996750	T997020
C	T996490	T996760	T997030
D	T996500	T996770	T997040
E	T996510	T996780	T997050
F	T996520	T996790	T997060
G	T996530	T996800	T997070
H	T996540	T996810	T997080
I	T996550	T996820	T997090
J	T996560	T996830	T997100
K	T996570	T996840	T997110
L	T996580	T996850	T997120
M	T996590	T996860	T997130
N	T996600	T996870	T997140
O	T996610	T996880	T997150
P	T996620	T996890	T997160
Q	T996630	T996900	T997170
R	T996640	T996910	T997180
S	T996650	T996920	T997190
T	T996660	T996930	T997200
U	T996670	T996940	T997210
V	T996680	T996950	T997220
W	T996690	T996960	T997230
X	T996700	T996970	T997240
Y	T996710	T996980	T997250
Z	T996720	T996990	T997260
A1	T996730	T997000	T997270

CAMA LITERA SIMPLE/DOBLE

DA7499E / DA7499W / DA7499G

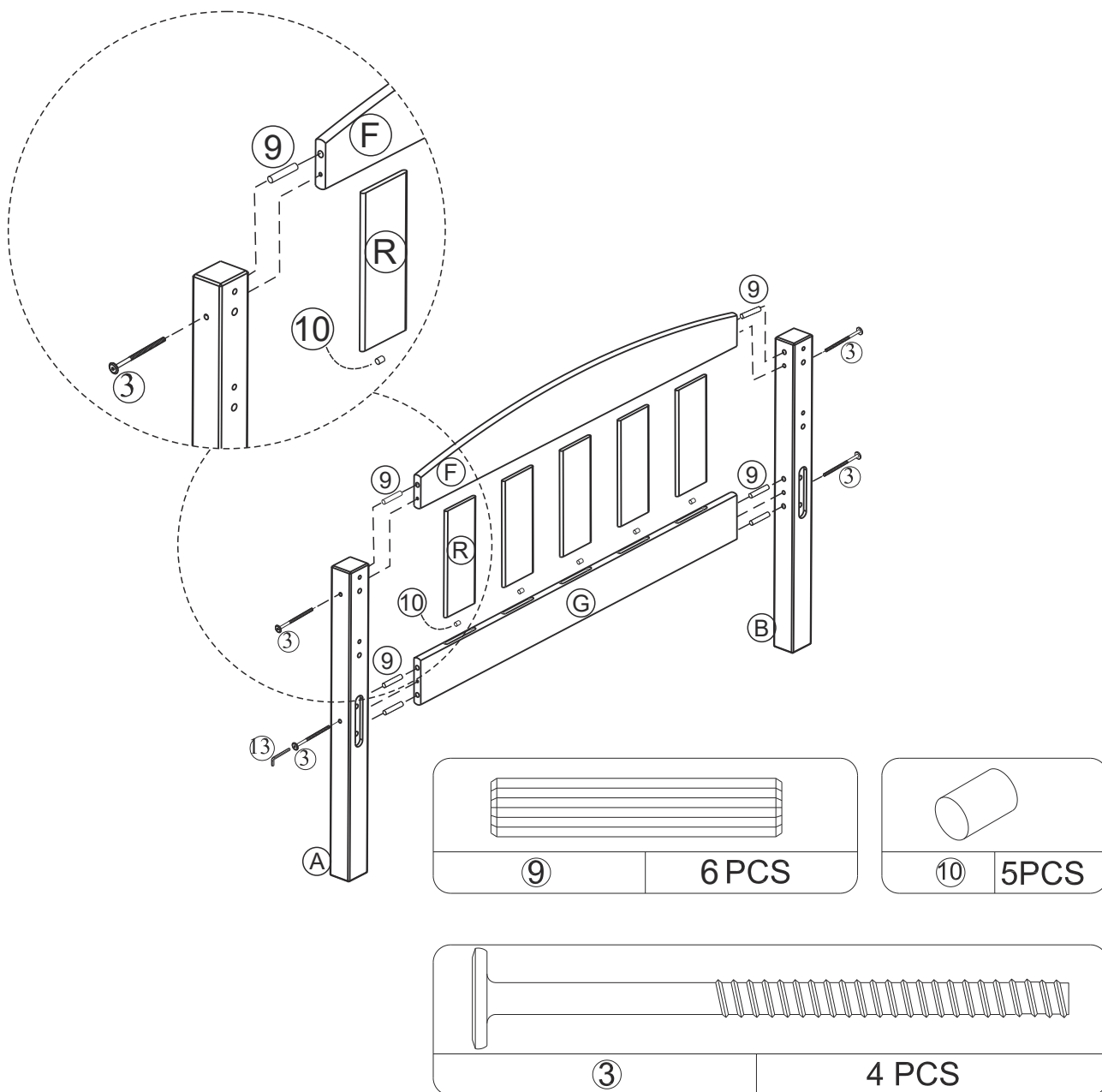

ETAPA 1

Uno de los travesaños superiores de cabecera (F) tiene una etiqueta, no lo utilice en esta etapa.

Inserte los toques (10) y los listones de la cabecera superior (R) en cada agujero del travesaño inferior de la cabecera (G) y ejerza una fuerza hacia abajo para fijarlos bien en su lugar.

Fije el travesaño superior de cabecera (F) a las liston cabecera inferior (R). Coloque tarugos de madera (9) en los extremos del travesaño superior de cabecera (F) y del travesaño inferior de cabecera (G).

Fije las patas superiores (A) y (B) con pernos conectores para madera (3). Utilice la llave Allen (13) para ajustar los conectores de la manera ilustrada.

CAMA LITERA SIMPLE/DOBLE

DA7499E / DA7499W / DA7499G

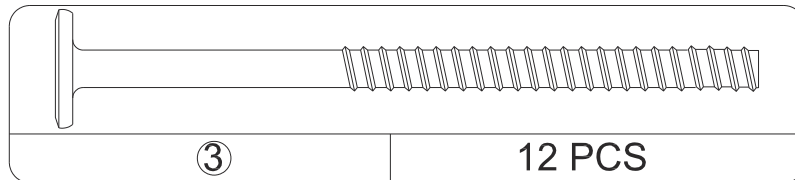
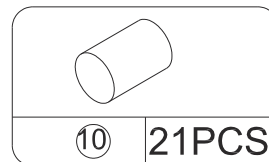
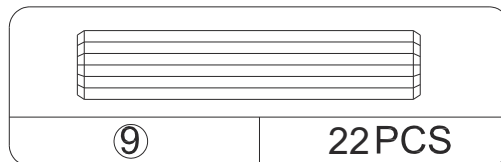
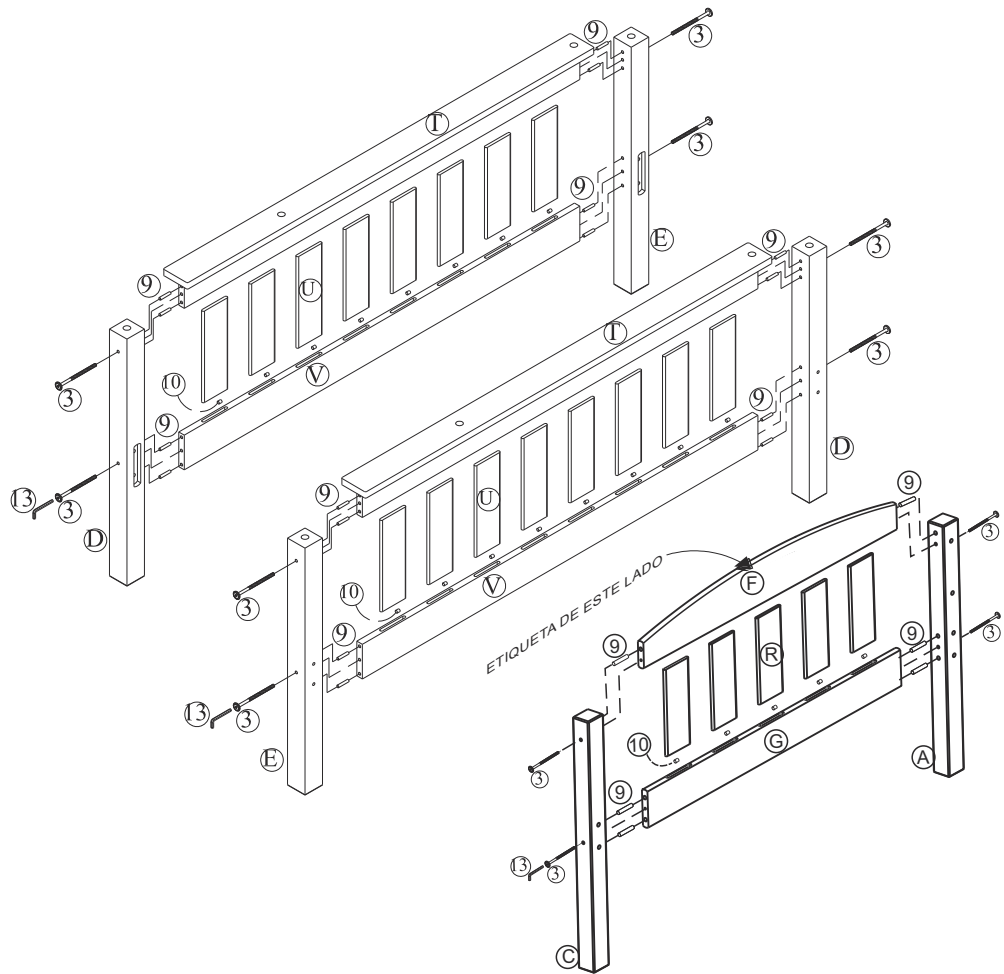

ETAPA 2

Repita la etapa anterior para armar las otras tres partes de cabecera. Asegúrese de utilizar las patas inferiores (D) y (E) para un par; (E) y (D) para otro par; y las patas superiores (C) y (A) para el último par.

NOTA: Utilice el travesaño superior de cabecera (F) que tiene la etiqueta entre las patas superiores (A) y (C). Vea la ilustración para colocar la etiqueta de manera correcta.

CAMA LITERA SIMPLE/DOBLE

DA7499E / DA7499W / DA7499G

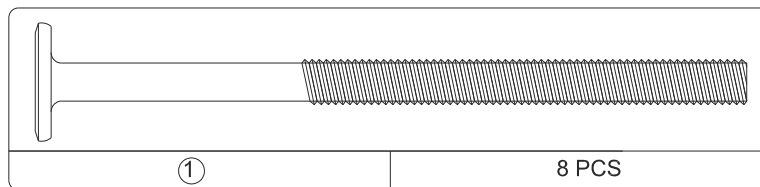
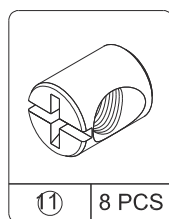
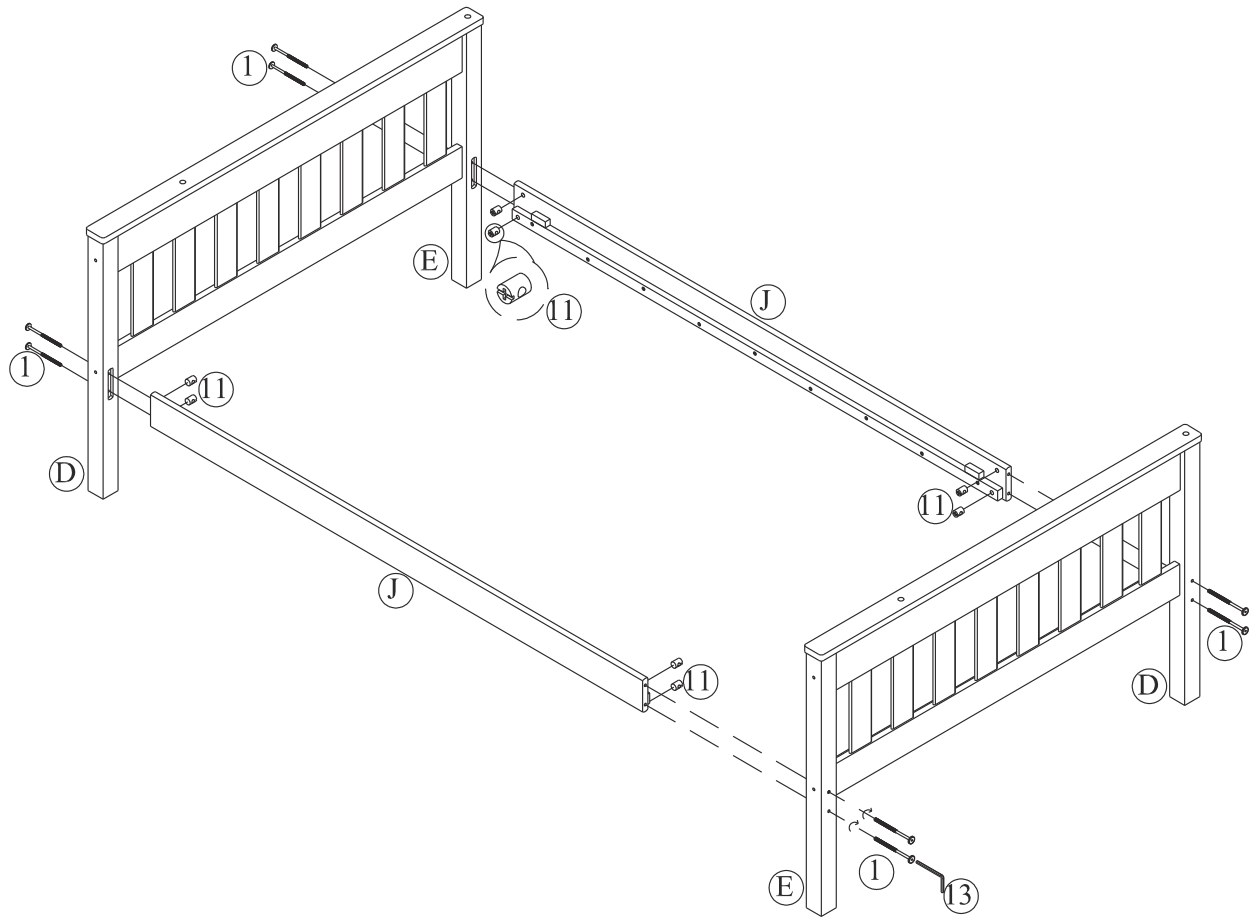

ETAPA 3

Coloque tuercas barrilete (11) en los largueros laterales inferiores (J) como ilustrado.

Fije las dos cabeceras con las patas inferiores (D y E) a los largueros laterales inferiores (J) con pernos conectores (1) y la llave Allen (13).

Nota: Ésta es la litera inferior.

CAMA LITERA SIMPLE/DOBLE

DA7499E / DA7499W / DA7499G

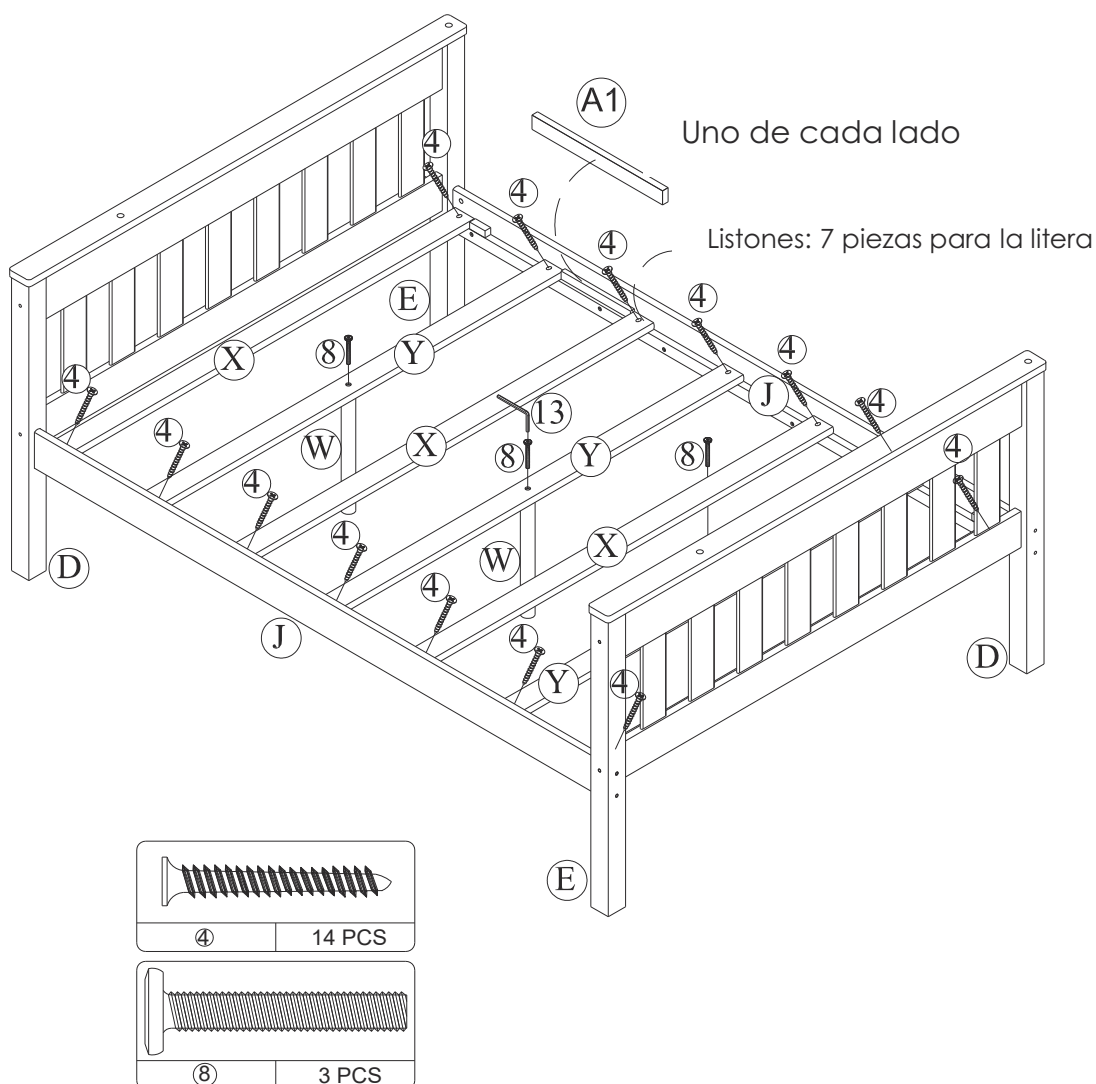

ETAPA 4

Fije las patas de apoyo (W) a los listones inferiores (Y) de la litera inferior con pernos de cabeza hexagonal (8) como ilustrado.

Fije un listón inferior (X) a los largueros laterales inferiores (J) con tornillos para madera de cabeza plana (4). Asegúrese de que el listón esté en contacto con las patas en los ángulos (lo más cerca posible de la cabecera).

Fije los otros listones (X e Y) a los largueros laterales inferiores (J) con tornillos para madera de cabeza plana (4) y un destornillador Phillips (no incluido). Utilice los separadores (A1) para espaciar los listones de manera uniforme como ilustrado.

NOTA: Si nota que alguno de los listones (X e Y) no está totalmente plano, asegúrese de colocarlos de manera que los listones (X e Y) tengan la curva hacia arriba en la parte central y hacia abajo en los extremos.

CAMA LITERA SIMPLE/DOBLE

DA7499E / DA7499W / DA7499G

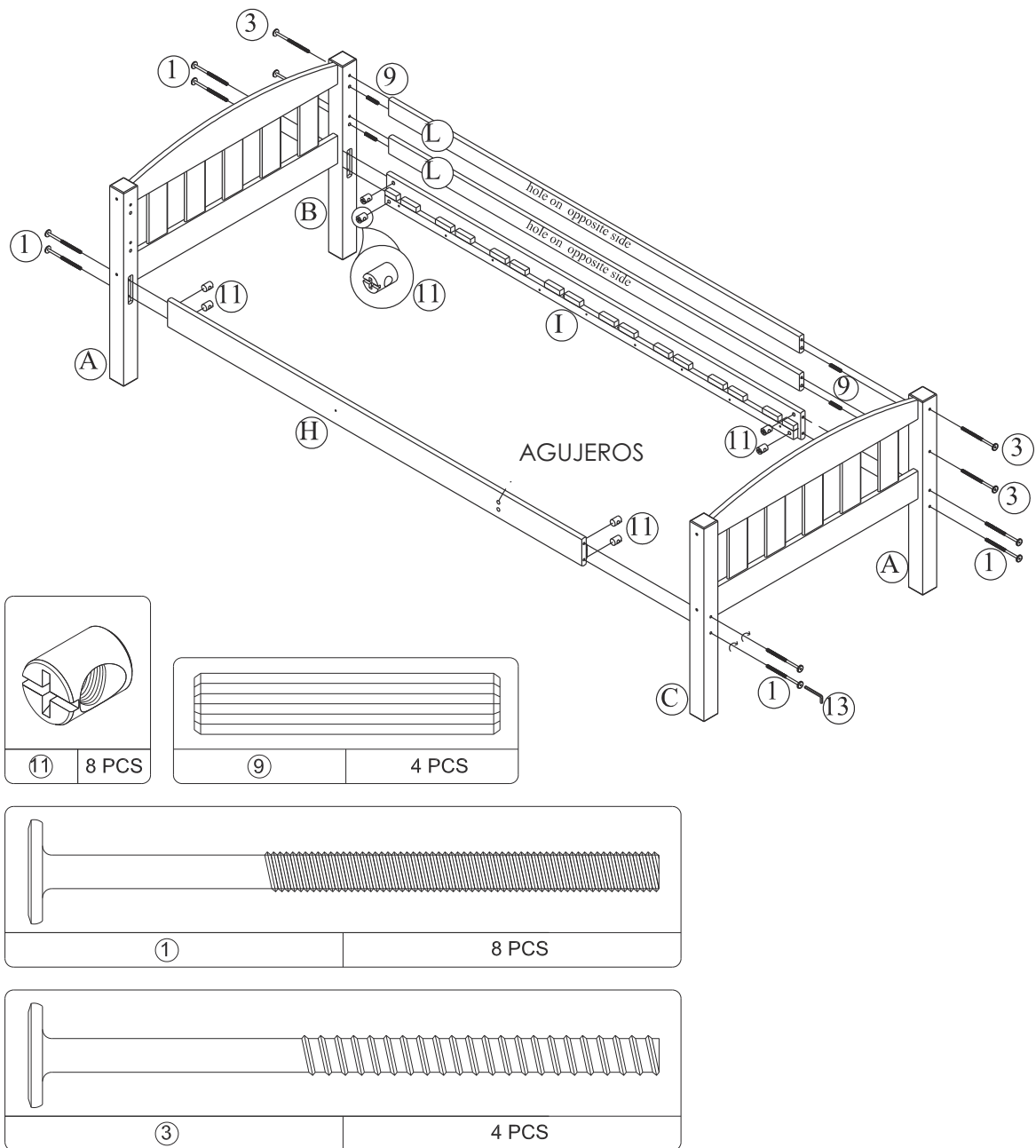

ETAPA 5

Coloque tarugos de madera (9) en cada extremo de los largueros largos de barandilla (L). Coloque tuercas barrilete (11) en los largueros laterales superiores (H e I). Fije dos largueros largos de barandilla (L) y dos largueros laterales superiores (H e I) a las patas superiores (A y B) y (A y C) como ilustrado, con pernos conectores (1) y (3). Utilice la llave Allen (13) para ajustar todos los conectores. Ésta es la litera superior.

CAMA LITERA SIMPLE/DOBLE

DA7499E / DA7499W / DA7499G

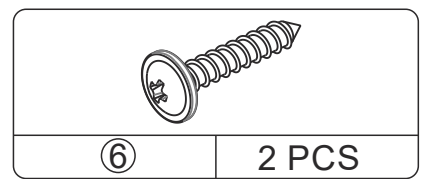
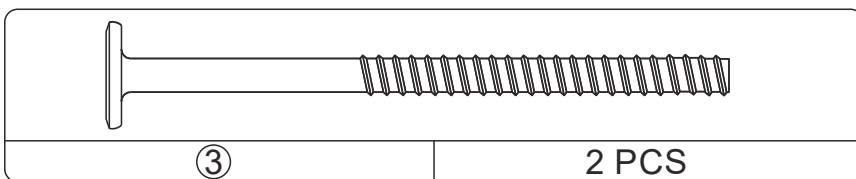
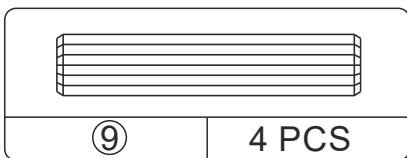
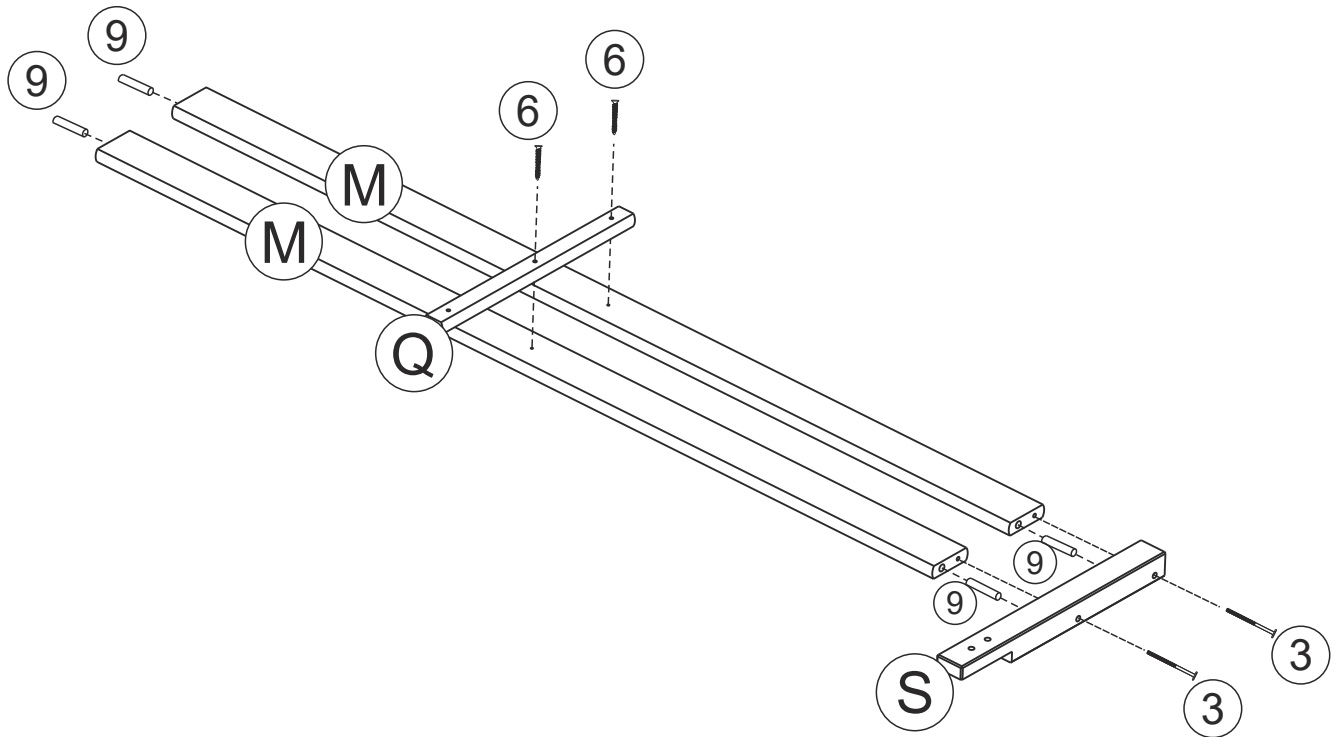

ETAPA 6

Coloque los tarugos (9) en cada extremo de los largueros cortos de barandilla (M). Fije la pata corta de barandilla (S) y una pata de barandilla (Q) a los largueros cortos de barandilla (M) con pernos conectores (3) y tornillos para madera de cabeza plana (6).

CAMA LITERA SIMPLE/DOBLE

DA7499E / DA7499W / DA7499G

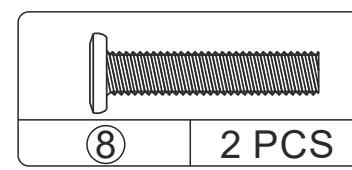
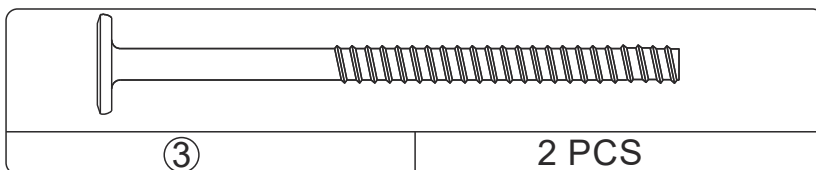
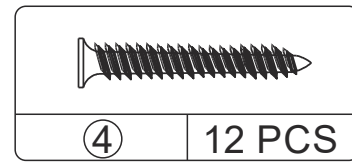
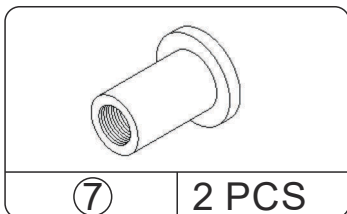
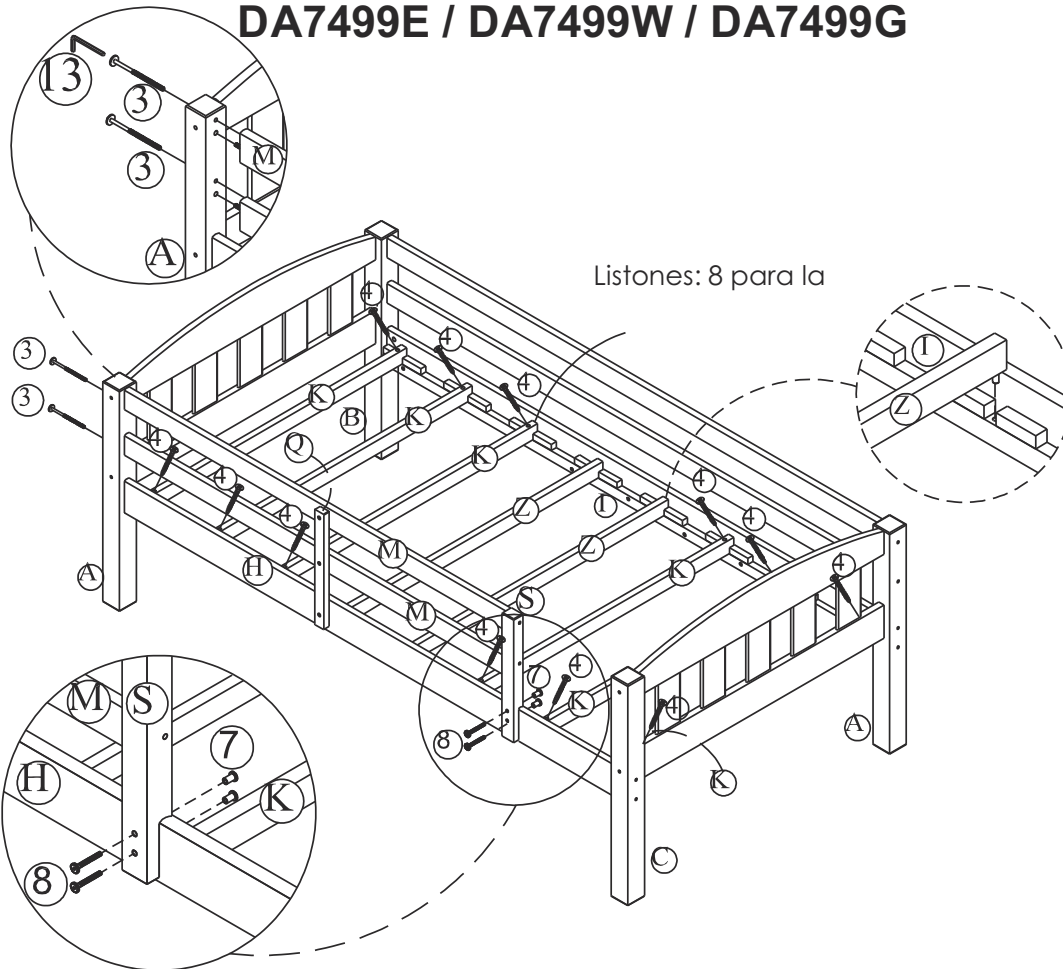

ETAPA 7

Fije la barandilla corta ya armada a la pata superior (A) con pernos conectores para madera (3), y al larguero lateral superior (H) con pernos de cabeza hexagonal (8) y tornillos de casquete (7) como ilustrado. Utilice la llave Allen (12) para ajustar los tornillos de casquete (7).

Fije un listón superior (K) a los largueros laterales superiores (H e I) de la litera superior con tornillos para madera de cabeza plana (4). Asegúrese de que el listón esté en contacto con las patas en los ángulos (lo más cerca posible de la cabecera). Fije los otros listones (K) a los largueros laterales superiores (H e I) con tornillos para madera de cabeza plana (4) y coloque los listones (Z) en los largueros laterales superiores (H e I) como ilustrado.

NOTA: Los listones (K y Z) deben estar colocados de manera que tengan la curva hacia arriba en la parte central y hacia abajo en los extremos.

CAMA LITERA SIMPLE/DOBLE

DA7499E / DA7499W / DA7499G

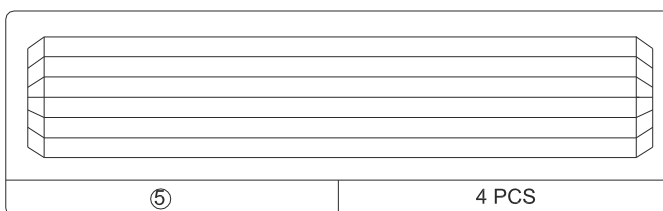
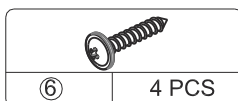
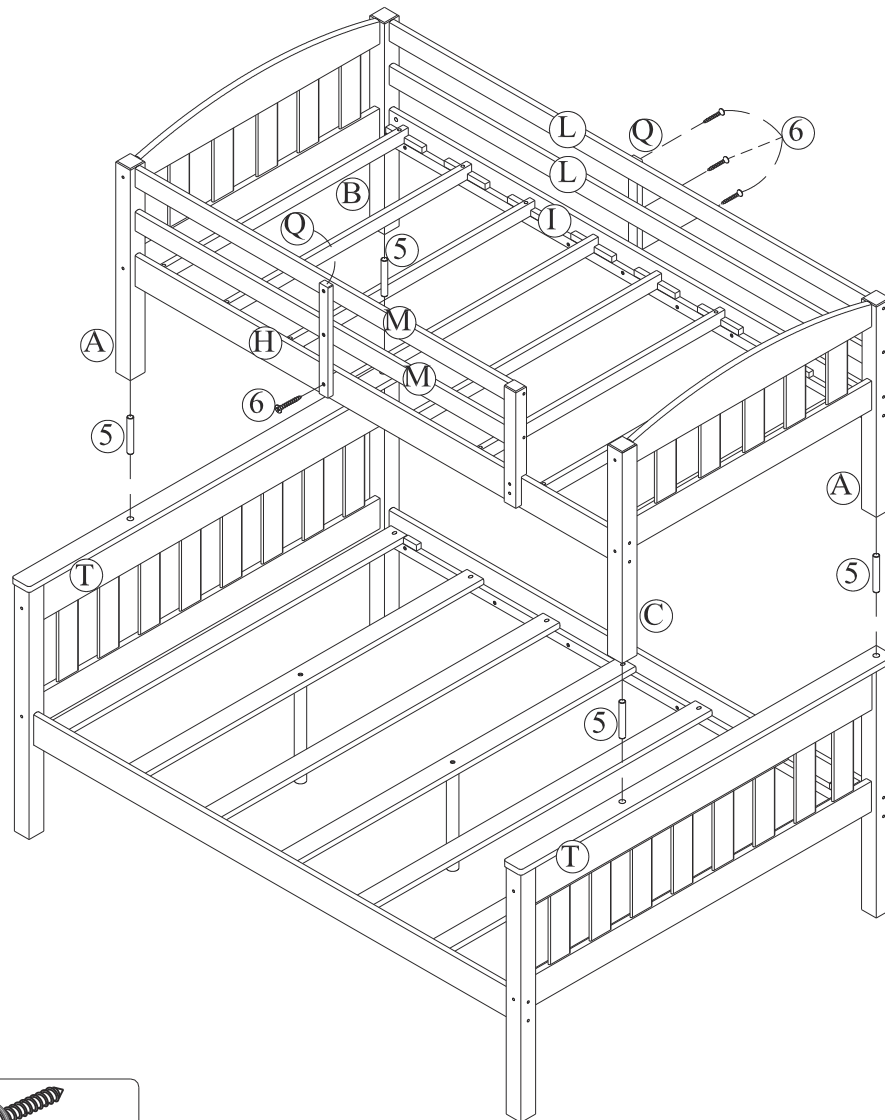

ETAPA 8

Fije la otra pata de barandilla (Q) a los largueros largos de barandilla (L) y al larguero lateral superior (I) con tornillos para madera de cabeza plana (6).

Fije la pata de barandilla (Q) (colocada en la Etapa 6) al larguero lateral superior (H) con tornillos para madera de cabeza plana (6) como ilustrado.

Coloque cuatro tarugos de madera (5) en los agujeros del travesaño superior de la cabecera inferior (T). Con la ayuda de otra persona, coloque la litera superior sobre la litera inferior.

CAMA LITERA SIMPLE/DOBLE

DA7499E / DA7499W / DA7499G

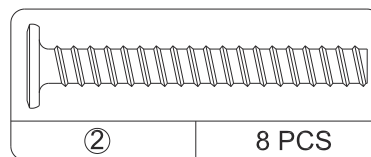
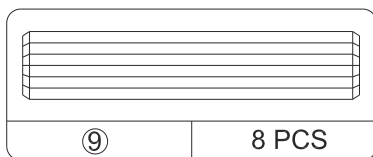
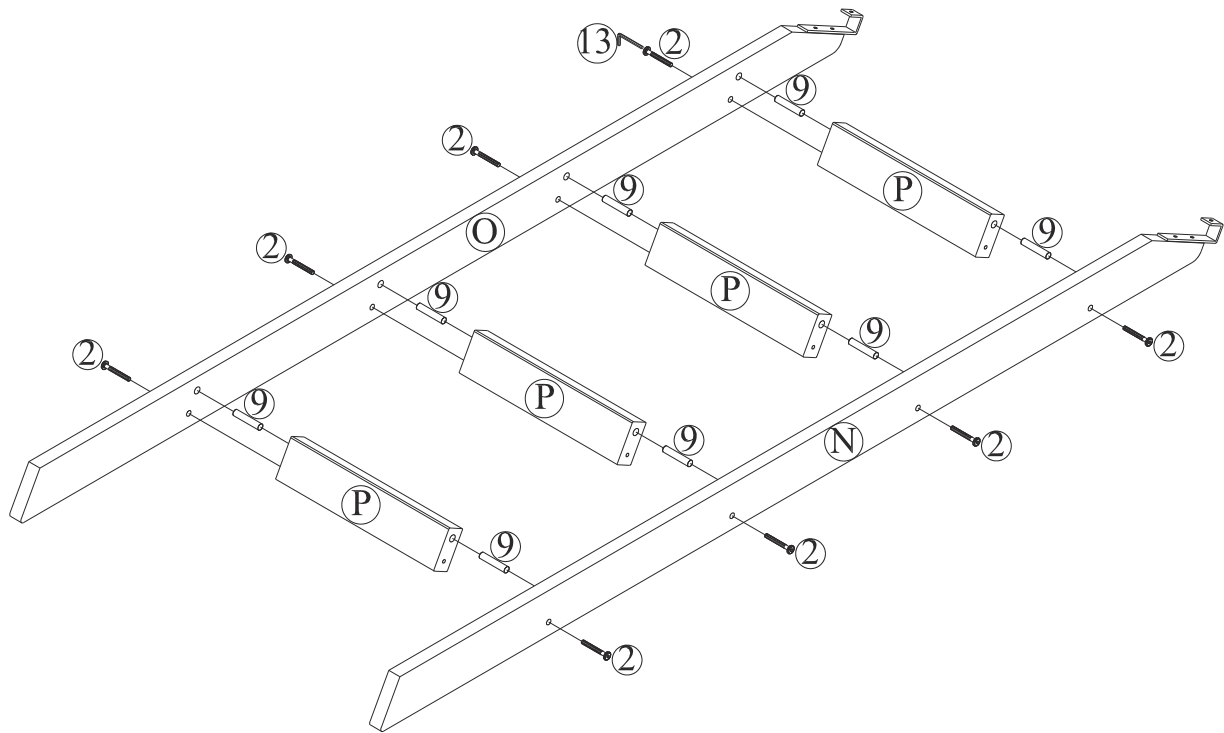

ETAPA 9

Coloque tarugos de madera (9) en los extremos de los escalones (P).
Fije el lado izquierdo de la escalera (N) y el lado derecho de la escalera (O) a los escalones (P) con pernos conectores para madera (2). Utilice la llave Allen (13) para ajustar los conectores como ilustrado.

CAMA LITERA SIMPLE/DOBLE

DA7499E / DA7499W / DA7499G

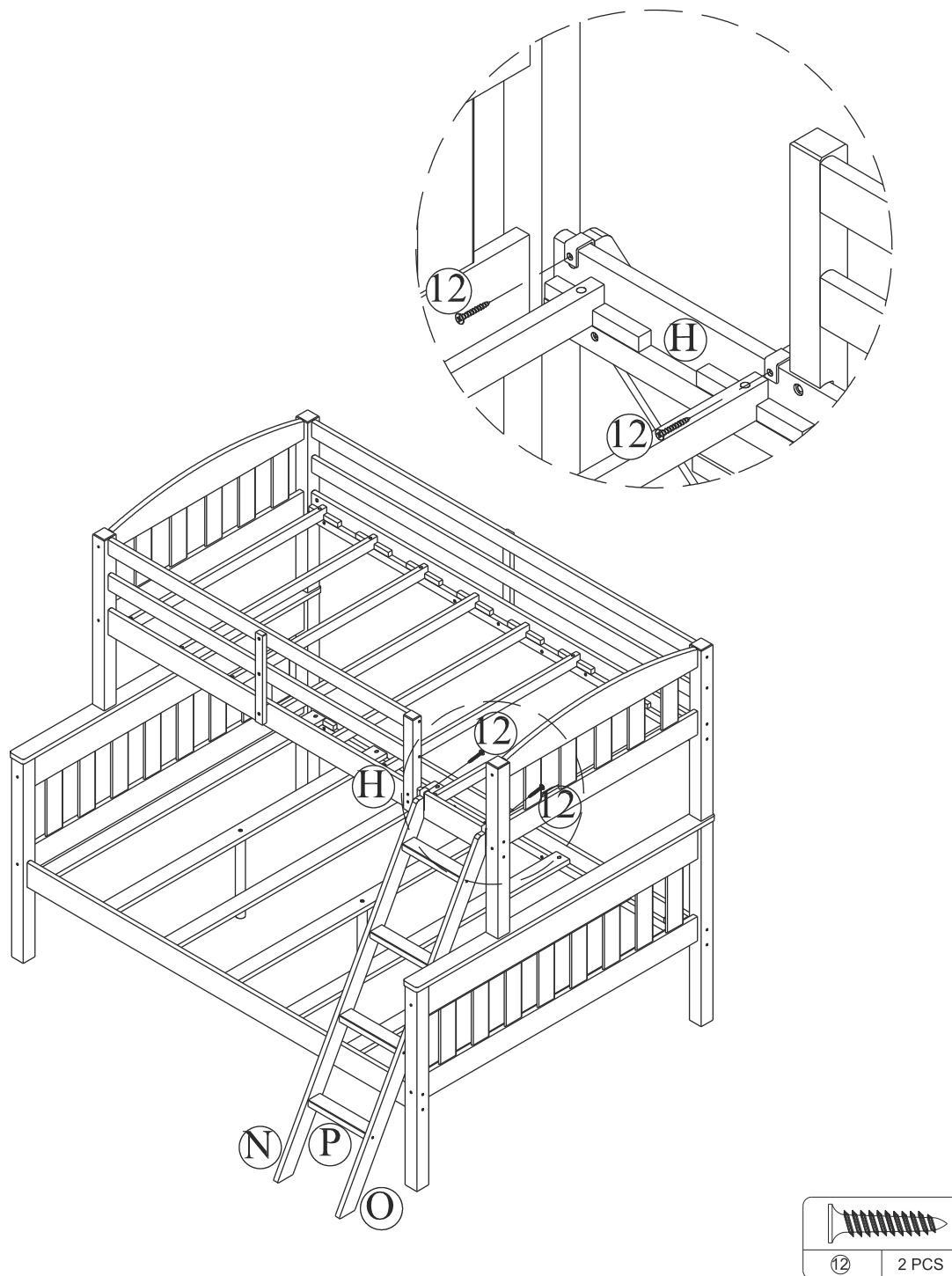

ETAPA 10

Fije la escalera al larguero lateral superior (H) con tornillos de cabeza plana (12) como ilustrado.

CAMA LITERA SIMPLE/DOBLE

DA7499E / DA7499W / DA7499G

Instrucciones para convertir la cama litera en dos camas

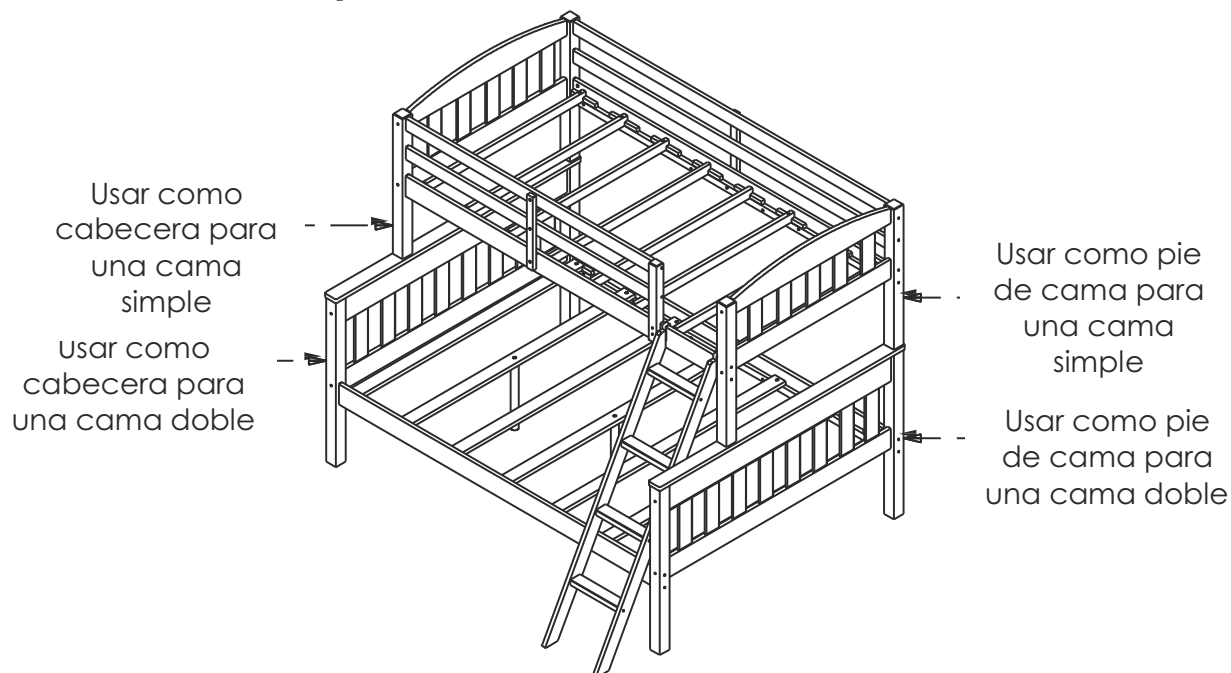

Cama Simple

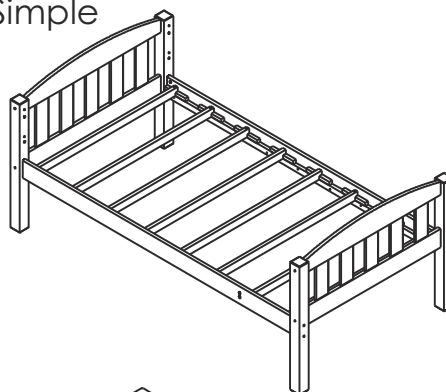

Cama Doble

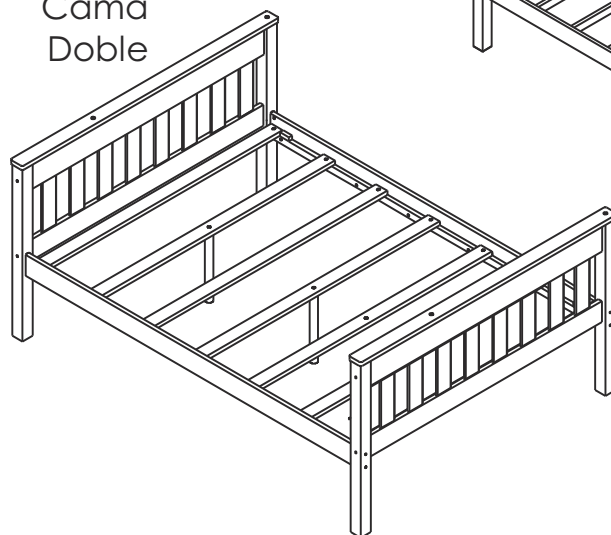

CONVERTIR LA LITERA EN UNA CAMA DOBLE Y UNA CAMA SIMPLE

Retire la escalera y todas las barandillas.

Con la ayuda de otra persona, separe la litera superior de la litera inferior y retire los tarugos de madera de las patas.

CAMA LITERA SIMPLE/DOBLE DA7499E / DA7499W / DA7499G

⚠ ADVERTENCIA: Este mueble está diseñado para ser utilizado únicamente con los productos y/o pesos máximos indicados. Su uso con otros productos y/o productos más pesados que los pesos máximos indicados puede causar inestabilidad o posibles lesiones.

NO PERMITA JUGAR SOBRE LA CAMA O DEBAJO DE ELLA Y PROHIBA SALTAR SOBRE LA CAMA

NO PERMITA A NIÑOS MENORES DE 6 AÑOS QUE UTILICEN LA LITERA SUPERIOR. LA CAMA ESTÁ DISEÑADA PARA NIÑOS DE EDADES ENTRE 6 AÑOS Y TEMPRANA ADOLESCENCIA.

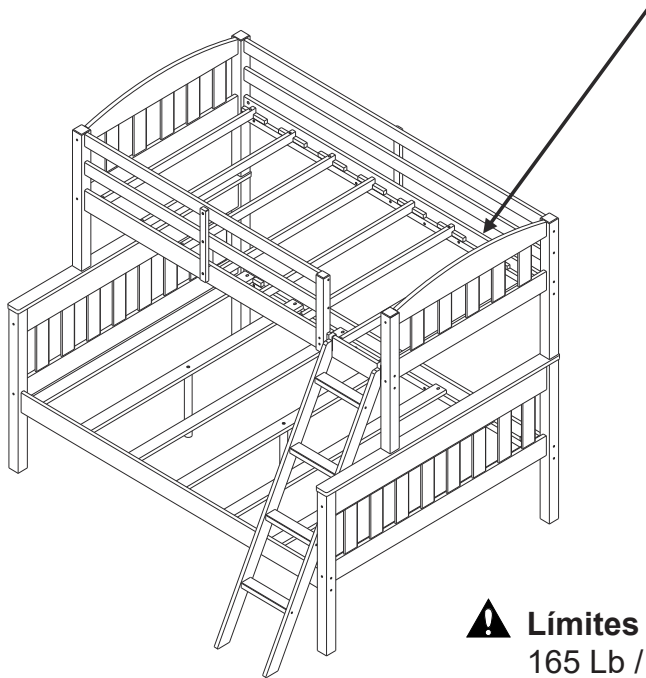

PARA EVITAR LESIONES, UTILICE ÚNICAMENTE COLCHONES DE RESORTE EN LAS DOS LITERAS.

**⚠ Límites de peso:
165 Lb / 75 kg Por nivel**

¡Listo! Ya ha acabado de armar su cama litera.

NO DEVUELVA EL PRODUCTO A LA TIENDA. Si falta una pieza o está dañada, comuníquese con nuestro Departamento de Servicio al Cliente. Reemplazaremos la pieza **SIN** costo alguno.

de Tel.: 1-800-267-1739
Correo electrónico : cs@dhpffurniture.com

LITS SUPERPOSÉS ET LITS JUMEAU/GRAND

Modèle No:	Code CUP:	Couleur:
DA7499E	0-65857-17298-0	Expresso
DA7499W	0-65857-17299-7	Blanc
DA7499G	0-65857-17755-8	Gris

Félicitations pour votre dernier achat d'un meuble ! Les meubles de la ligne **Dorel Living** ont été conçus ayant en tête la qualité, la commodité et le style. Nous sommes convaincus que ce meuble vous servira durant de nombreuses années avec un confort exceptionnel.

Nous vous encourageons à vous familiariser avec les caractéristiques de votre nouveau meuble avant de commencer l'assemblage ; prenez donc quelques minutes pour lire ce manuel. Il contient de l'information importante concernant notre garantie et des conseils d'entretien pour vous assurer de garder votre meuble aussi beau qu'aux premiers jours.

Pour trouver d'autres idées inspirantes, veuillez visiter notre site web à www.dorelliving.com
Vous pouvez aussi souscrire à notre page **Facebook et Instagram** pour être à la fine pointe de toutes les dernières tendances.

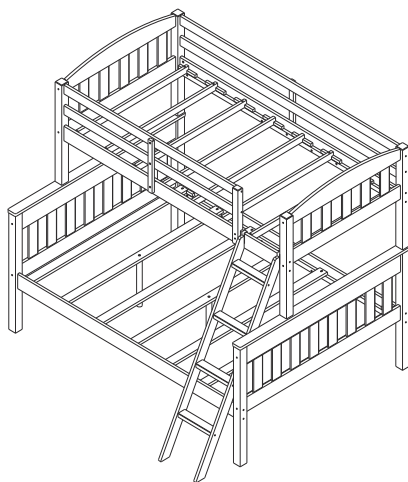

▲ Limite de Poids:
165 Lb / 75 kg Par Niveau

Date d'achat: ____ / ____ / ____

Numéro de lot: _____

(sur la boîte)

Numéro du Manuel d'Instructions : B34DA7499001 - 136832

Des questions, des préoccupations, des pièces manquantes? La satisfaction du client est importante pour nous chez Dorel Asia. **CONTACTEZ NOTRE SERVICE À LA CLIENTÈLE AVANT DE RETOURNER LE PRODUIT AU DÉTAILLANT.**

cs@dhpffurniture.com

1-800-267-1739

Lundi - Vendredi 9:00 am to 9:00 pm (Heure de l'Est)

Samedi 10 am to 6:30 pm (Heure de l'Est)

Dimanche 11 am to 7 pm (Heure de l'Est)

DHP Consumer Services

12345 Albert-Hudon Boulevard, Suite 100

Montreal, Québec, Canada, H1G 3L1

NOTE: CE MANUEL D'INSTRUCTIONS CONTIENT INFORMATION DE SÉCURITÉ IMPORTANTE. VEUILLEZ LE LIRE ET LE CONSERVER POUR RÉFÉRENCE ULTÉRIEURE.

SERVICE À LA CLIENTÈLE

Vous pouvez également nous contacter en écrivant à l'adresse ci-dessous. S'il vous plaît inclure le numéro de modèle du produit, la couleur et une description détaillée de votre demande.

DHP Consumer Services
12345 Albert-Hudon Boulevard, Suite 100
Montreal, Québec
Canada, H1G 3L1

NOTES ET INSTALLATION

- LIRE ATTENTIVEMENT CHAQUE ÉTAPE AVANT DE COMMENCER. IL EST TRÈS IMPORTANT QUE CHAQUE ÉTAPE SOIT EXÉCUTÉE DANS L'ORDRE APPROPRIÉ. SI CES ÉTAPES NE SONT PAS SUIVIES DANS L'ORDRE, DES DIFFICULTÉS D'ASSEMBLAGE SE PRODUIRONT ET PEUVENT ENTRAÎNER DES BLESSURES.
- **ATTENTION:** ASSEMBLAGE PAR UN ADULTE REQUIS.
- ASSUREZ-VOUS QUE TOUTES LES PIÈCES SONT INCLUSES. TRAVAILLEZ DANS UN ENDROIT SPACIEUX, PRÉFÉRABLEMENT SUR UNE SURFACE LISSE ET DOUCE.
- DEUX PERSONNES SONT REQUISES POUR L'ASSEMBLAGE.

- LA PLUPART DES PLANCHES SONT ÉTIQUETÉES OU ESTAMPILLÉES SUR LE CÔTÉ NON-FINI.
- UN TOURNEVIS À TÊTE CRUCIFORME (NON INCLUS) EST NÉCESSAIRE.
- UN MAILLET EN CAOUTCHOUC (NON INCLUS) EST RECOMMANDÉ POUR FACILITER L'ASSEMBLAGE.
- LE LIT EST CONÇU POUR DES ENFANTS DE 6 ANS JUSQU'À JEUNES ADOLESCENTS.

SOIN, NETTOYAGE ET ENTRETIEN

Époussetez régulièrement avec un chiffon doux et sec. Nous ne recommandons pas l'utilisation de produits nettoyants ou de cire sur notre mobilier laqué car cela pourrait endommager la finition. Gardez les solvants, alcools, vernis à ongles et décapants loin des surfaces de votre mobilier en bois franc.

Vérifiez les boulons/vis périodiquement et serrez-les si nécessaire.

GARANTIE LIMITÉE DE 1 AN

Dorel garantit que son produit est exempt de défauts de matériaux et de fabrication et accepte de remédier à un tel défaut. Cette garantie couvre un (1) an à partir de la date d'achat originale. Cette garantie est valable uniquement sur présentation d'une preuve d'achat. Cette garantie se limite exclusivement à la réparation ou au remplacement de pièces défectueuses du mobilier et aucun travail d'assemblage n'est inclus. Cette garantie ne s'applique pas à un produit qui a été assemblé incorrectement, soumis à une mauvaise utilisation ou abus, ou qui a été modifié ou réparé de quelque façon. L'usure, les déchirures ou la décoloration du tissu ne sont pas couverts par cette garantie (le cas échéant). Cette garantie vous donne des droits légaux spécifiques et vous pouvez également avoir d'autres droits qui varient d'un État à l'autre ou d'une province à l'autre.



AVERTISSEMENT: Si ce produit est endommagé, et/ou des pièces sont brisées ou manquantes, NE PAS UTILISER.





AVERTISSEMENT - Lit superposé : Une place / Deux places

- **RISQUE D'ÉTRANGLEMENT** - Ne jamais placer ou suspendre des articles sur aucune partie du lit superposé qui ne sont pas conçus pour être utilisés avec ce lit; par exemple, mais n'étant pas limité à, des crochets, des ceintures, et des cordes à sauter.
- Suivez les informations sur les étiquettes d'avertissement apposées à l'extrémité de la structure du lit superposé et sur la boîte. Ne pas enlever l'étiquette d'avertissement apposée sur le lit.
- La plateforme du matelas est conçue pour supporter un matelas sans avoir besoin d'un support de matelas ou d'un sommier.
- Toujours utiliser la grandeur de matelas ou de support de matelas recommandée, ou les deux, afin de prévenir la possibilité de blessures ou de chutes.
- **UTILISEZ UNIQUEMENT DES MATELAS À RESSORTS SUR LE LIT DU BAS ET DU HAUT AFIN DE PRÉVENIR LES BLESSURES.**
- Utilisez uniquement des matelas de **74"-75"** de long par **37 1/2" - 38 1/2"** de large sur le lit du haut et d'au moins 74"-75" de long par 53"-54" de large sur le lit du bas. Assurez-vous que l'épaisseur des matelas n'excède pas **6"**. La surface du matelas doit arriver au moins à **5" (127 mm)** sous le bord supérieur des barrières.
- Ne pas permettre aux enfants de moins de **6** ans d'utiliser le lit du haut.
- Toujours installer les barrières sur les deux longs côtés du lit du haut. Si le lit superposé est placé près d'un mur, la barrière qui couvre la pleine longueur du lit doit être placée contre le mur pour éviter que l'enfant reste coincé entre le mur et le lit (applicable pour les lits superposés avec des barrières pleine grandeur sur un côté).
- Vérifiez périodiquement et assurez-vous que la barrière, l'échelle et les autres composants sont dans la bonne position, exempts de dommages, et que toutes les connexions sont bien serrées.
- Interdire les jeux brutaux sur ou sous le lit et interdire de sauter sur le lit.
- Ne pas substituer de pièces. Contactez le fabricant ou le revendeur pour des pièces de remplacement.
- L'utilisation d'une veilleuse procure une sécurité supplémentaire pour un enfant utilisant le lit du haut.
- L'utilisation de matelas d'eau ou de matelas d'air est interdite.
- Toujours utiliser l'échelle pour monter ou descendre du lit supérieur.
- Interdire plus d'une personne sur le lit du haut.
- Conservez ces instructions pour référence ultérieure.

LITS SUPERPOSÉS ET LITS JUMEAU/GRAND

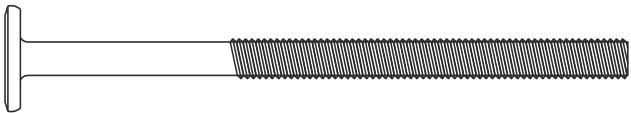
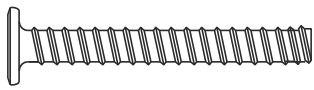
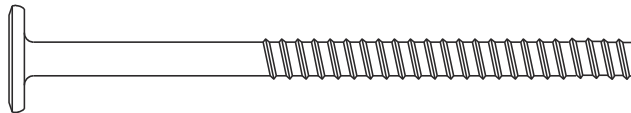
DA7499E / DA7499W / DA7499G

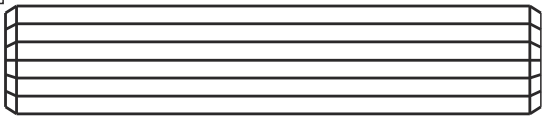
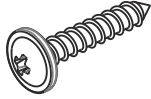
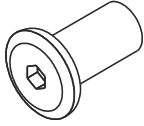
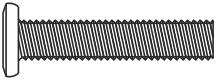
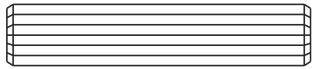
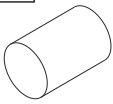
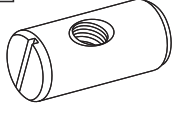
LISTE DE QUINCAILLERIE

<p>1</p>  <p>Ø1/4" x 100mm</p>	<p>2</p>  <p>Ø6.5mm x 48mm</p>		
<p>CONNECTEUR (4 mm TÊTE HEXAGONALE) 16 PCES</p>	<p>CONNECTEUR À BOIS (4 mm TÊTE HEXAGONALE) 8 PCE</p>		
<p>3</p>  <p>Ø6.5mm x 100mm</p>	<p>4</p>  <p>Ø4mm x 35mm</p>		
<p>CONNECTEUR À BOIS (4 mm TÊTE HEXAGONALE) 24 PCES</p>	<p>VIS À BOIS À TÊTE PLATE 26 PCES</p>		
<p>5</p>  <p>Ø15mm x 100mm</p>	<p>6</p>  <p>Ø 4mm x 35mm</p>		
<p>GOUJON DE BOIS 4 PCES</p>	<p>VIS À BOIS À TÊTE FLANG 6 PCES</p>		
<p>7</p>  <p>Ø9mm x 17mm</p>	<p>8</p>  <p>Ø1/4" x 32mm</p>	<p>9</p>  <p>Ø10mm x 50mm</p>	<p>10</p> 
<p>CHAPEAU À VIS HEXAGONAL 2 PCES</p>	<p>BOULON À TÊTE HEXAGONALE 5 PCES</p>	<p>GOUJON DE BOIS 44 PCES</p>	<p>ARRÊT 26 PCES</p>
<p>11</p>  <p>Ø11.8mm x 15mm</p>	<p>12</p>  <p>Ø4mm x 19mm</p>	<p>13</p> 	
<p>ÉCROU À MANCHON FILETÉ 16 PCES</p>	<p>VIS À TÊTE PLATE 2 PCES</p>	<p>CLÉ ALLEN 1 PCE</p>	

LITS SUPERPOSÉS ET LITS Jumeau/Grand

DA7499E / DA7499W / DA7499G

QUINCAILLERIE

DA7499E (Expresso) DA7499G (Gris)	# de Paquet : <input checked="" type="checkbox"/> TDA7499E-00
DA7499W (Blanc)	# de Paquet : <input type="checkbox"/> TDA7499W-00



Remarque: Sauf indication contraire dans les instructions, ne pas resserrer complètement les vis et les boulons, jusqu'à ce que l'assemblage soit terminé.







Les vis et boulons utilisés durant chaque étape sont illustrés en taille réelle au coin inférieur droit de la page.

LITS SUPERPOSÉS ET LITS JUMEAU/GRAND

DA7499E / DA7499W / DA7499G

Liste de pièces

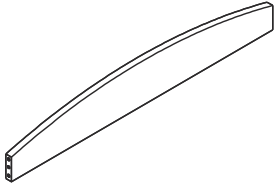

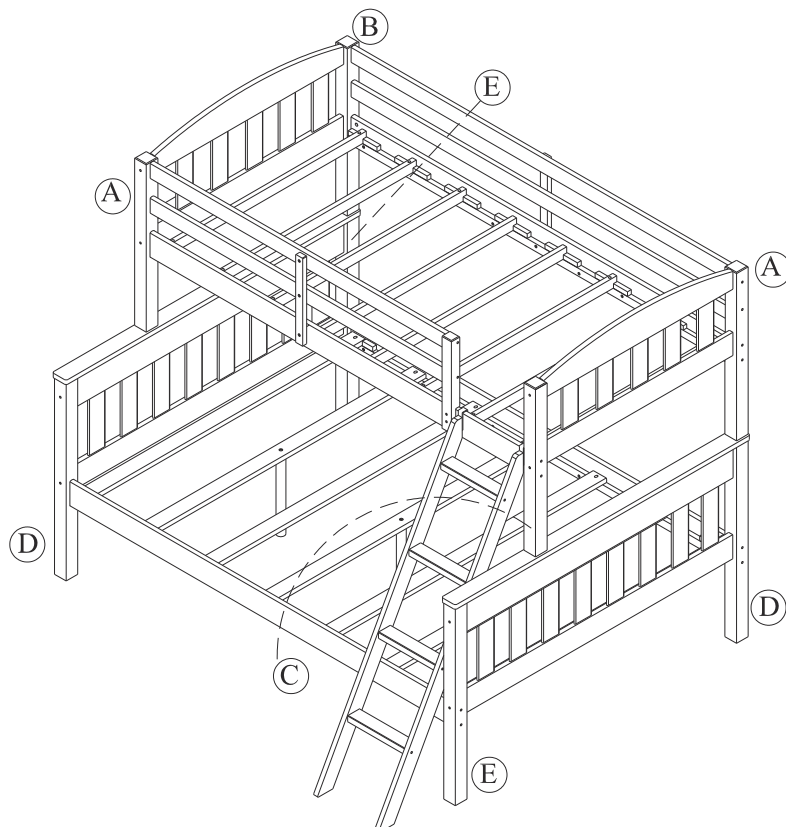
<p>A</p> 	<p>B</p> 	<p>C</p> 
<p>PIED SUPÉRIEUR 2 PCES</p>	<p>PIED SUPÉRIEUR 1 PCE</p>	<p>PIED SUPÉRIEUR 1 PCE</p>
<p>D</p> 	<p>E</p> 	<p>F</p> 
<p>PIED INFÉRIEUR 2 PCES</p>	<p>PIED INFÉRIEUR 2 PCES</p>	<p>TRAVERSE SUPÉRIEURE DE TÊTE DE LIT 2 PCES</p>



LITS SUPERPOSÉS ET LITS JUMEAU/GRAND



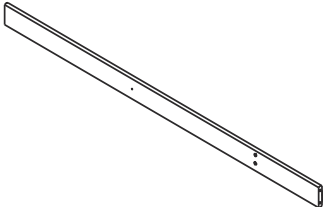
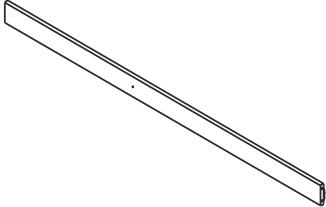
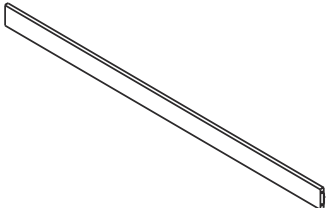
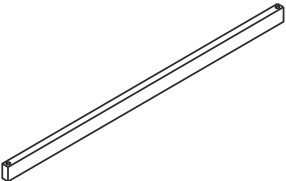
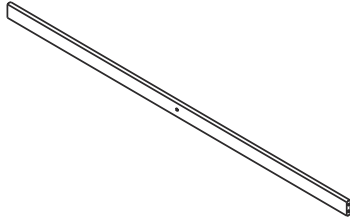
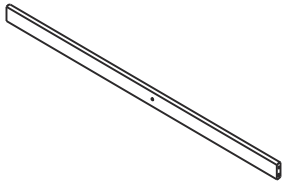
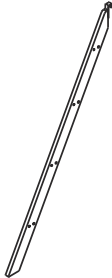
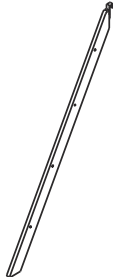
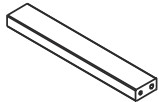



DA7499E / DA7499W / DA7499G

LISTE DE PIÈCES

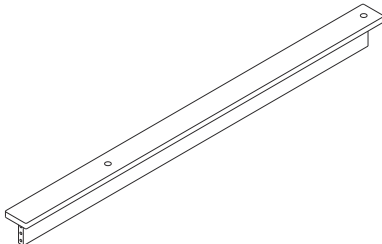
<p>G</p> 	<p>H</p> 	<p>I</p> 
<p>TRAVERSE INFÉRIEURE DE TÊTE DE LIT - 2 PCES</p>	<p>CÔTÉ DE LIT SUPÉRIEUR (AVEC 3 TROUS) - 1 PCE</p>	<p>CÔTÉ DE LIT SUPÉRIEUR (AVEC 1 TROU) - 1 PCE</p>
<p>J</p> 	<p>K</p> 	<p>L</p> 
<p>CÔTÉ DE LIT INFÉRIEUR 2 PCES</p>	<p>LATTE SUPÉRIEUR 6 PCES</p>	<p>BARRIÈRE LONGUE 2 PCES</p>
<p>M</p> 	<p>N</p> 	<p>O</p> 
<p>BARRIÈRE COURTE 2 PCES</p>	<p>MONTANT GAUCHE D'ÉCHELLE 1 PCE</p>	<p>MONTANT DROIT D'ÉCHELLE 1 PCE</p>
<p>P</p> 	<p>Q</p> 	<p>R</p> 
<p>MARCHE DE L'ÉCHELLE 4 PCES</p>	<p>PIED DE BARRIÈRE 2 PCES</p>	<p>LATTE TÊTE DE LIT SUPÉRIEUR 10 PCES</p>

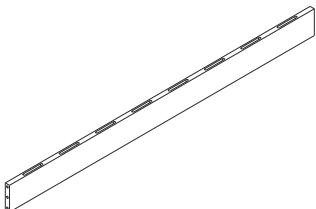
LITS SUPERPOSÉS ET LITS JUMEAU/GRAND

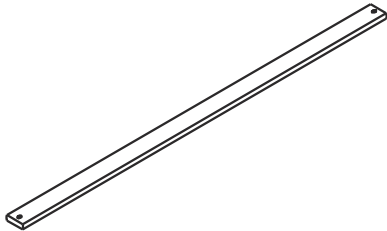
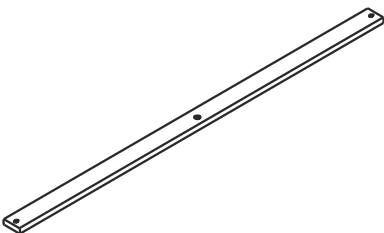
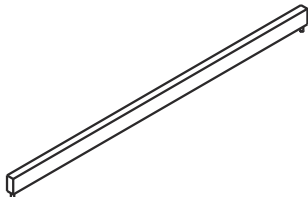
DA7499E / DA7499W / DA7499G

<p>S</p> 	<p>T</p> 	<p>U</p> 
<p>PIED DE BARRIÈRE COURTE 1 PCE</p>	<p>TRAVERSE INFÉRIEURE DE TÊTE DE LIT 2 PCES</p>	<p>LATTE TÊTE DE LIT INFÉRIEURE 16 PCES</p>
<p>V</p> 	<p>W</p> 	<p>X</p> 
<p>TRAVERSE INFÉRIEURE DE TÊTE DE LIT 2 PCES</p>	<p>PIED DE SUPPORT 3 PCES</p>	<p>LATTE INFÉRIEURE (SANS TROU) 4 PCES</p>
<p>Y</p> 	<p>Z</p> 	<p>A1</p> 
<p>LATTE INFÉRIEURE (AVEC 1 TROU) 3 PCES</p>	<p>LATTE SUPÉRIEUR 2 PCES</p>	<p>BARRE D'ESPACEMENT 2 PCES</p>

LITS SUPERPOSÉS ET LITS Jumeau/Grand

DA7499E / DA7499W / DA7499G

PIÈCES

Pour des pièces de rechange, visitez www.dhpfurniture.com/fre/replacement-parts

IMPORTANT: La liste des références ci-dessous est propre à votre produit. Veuillez l'avoir sous la main lorsque vous appelez pour des pièces de rechange.



Avant de jeter les boîtes en carton, assurez-vous qu'elles soient vides. Vérifiez que vous avez reçu tous les composants nécessaires à l'assemblage en les comparant avec le tableau des pièces (illustrations disponibles dans la section en anglais).

LISTE DES PIÈCES			
ÉTIQUETTE DES PIÈCES	DA7499E (Expresso)	DA7499W (Blanc)	DA7499G (Gris)
A	T996470	T996740	T997010
B	T996480	T996750	T997020
C	T996490	T996760	T997030
D	T996500	T996770	T997040
E	T996510	T996780	T997050
F	T996520	T996790	T997060
G	T996530	T996800	T997070
H	T996540	T996810	T997080
I	T996550	T996820	T997090
J	T996560	T996830	T997100
K	T996570	T996840	T997110
L	T996580	T996850	T997120
M	T996590	T996860	T997130
N	T996600	T996870	T997140
O	T996610	T996880	T997150
P	T996620	T996890	T997160
Q	T996630	T996900	T997170
R	T996640	T996910	T997180
S	T996650	T996920	T997190
T	T996660	T996930	T997200
U	T996670	T996940	T997210
V	T996680	T996950	T997220
W	T996690	T996960	T997230
X	T996700	T996970	T997240
Y	T996710	T996980	T997250
Z	T996720	T996990	T997260
A1	T996730	T997000	T997270

LITS SUPERPOSÉS ET LITS JUMEAU/GRAND

DA7499E / DA7499W / DA7499G

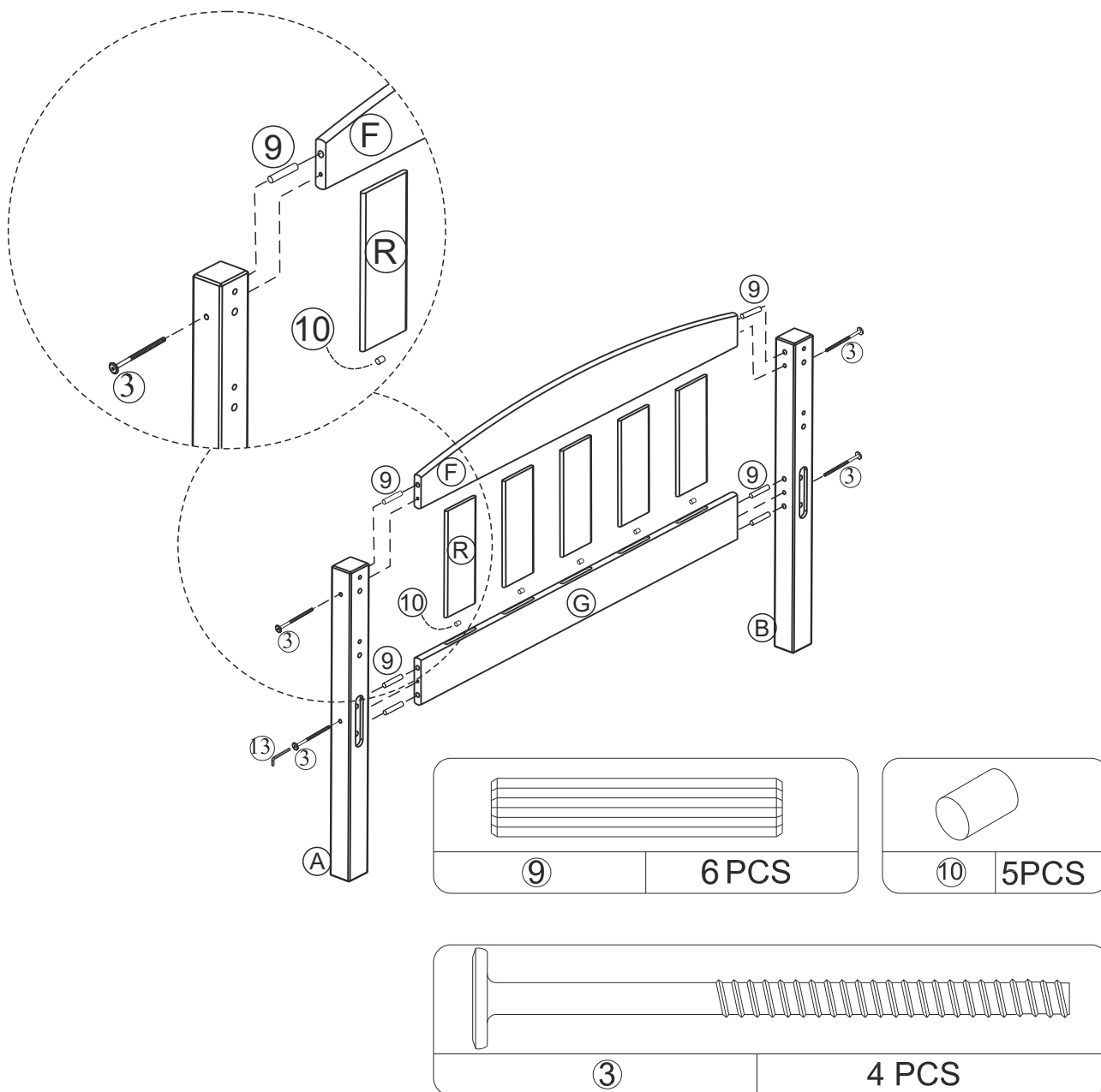

ÉTAPE 1

Une des traverses supérieures de tête de lit (F) porte une étiquette; ne pas l'utiliser à cette étape.

Insérez les arrêts (10) et les lattes de la tête de lit supérieure (R) dans chaque trou de la barre transversale inférieure de la tête de lit (G) et poussez vers le bas pour bien les fixer à leur place.

Fixez le traverse supérieure de tête de lit (F) a les latte tête de lit supérieure (R).

Insérez des goujons de bois (9) dans les extrémités de la traverse supérieure de tête de lit (F) et de la traverse inférieure de tête de lit (G).

Fixez les pieds supérieurs (A) et (B) à l'aide de connecteurs à bois (3). Utilisez la clé Allen (13) pour serrer les connecteurs comme illustré.

LITS SUPERPOSÉS ET LITS JUMEAU/GRAND

DA7499E / DA7499W / DA7499G

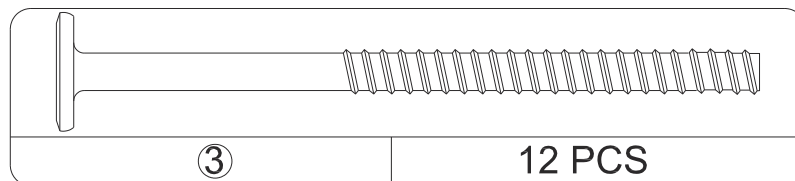
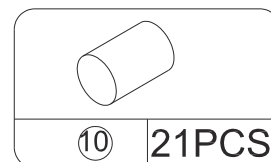
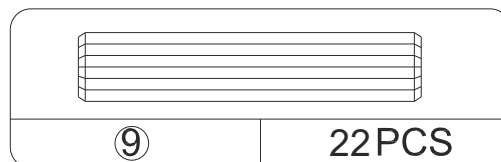
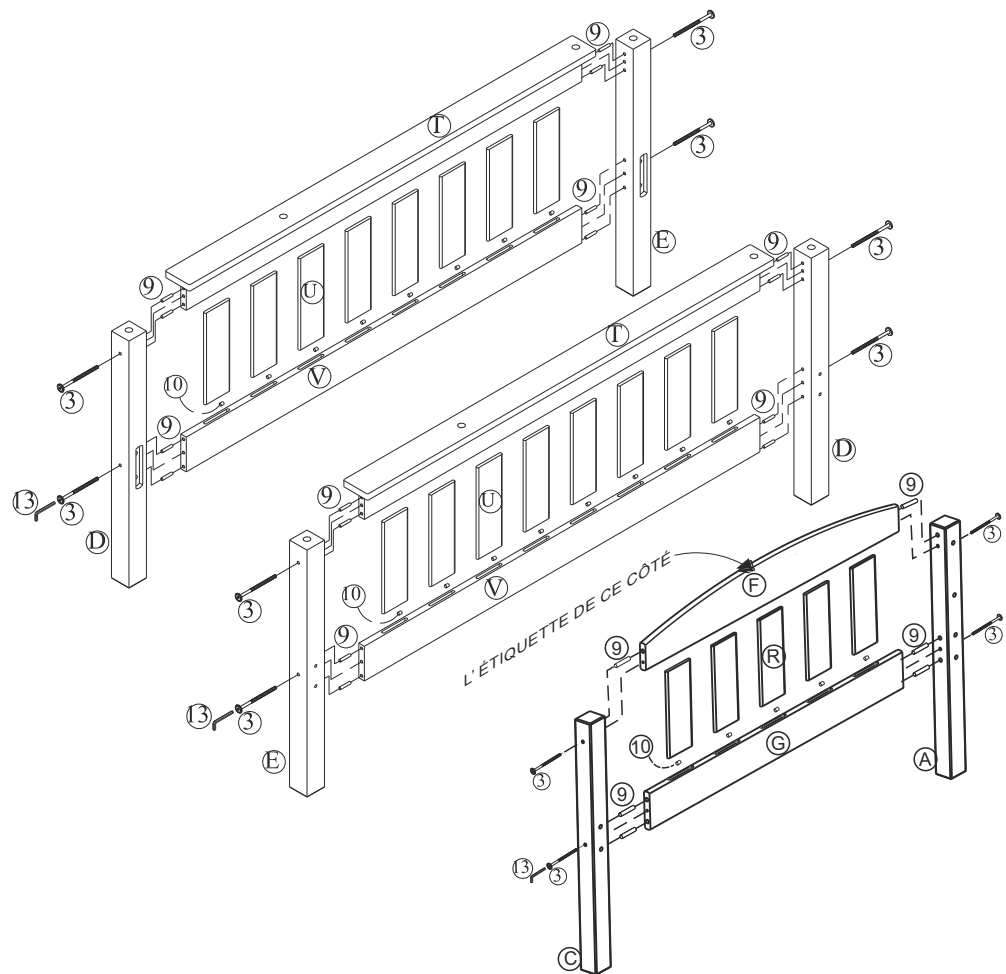

ÉTAPE 2

Répétez l'étape précédente pour assembler les trois têtes de lit qui restent. Assurez-vous de mettre ensemble les pieds inférieurs (D) et (E) pour former une paire; (E) et (D) pour une autre, et les pieds supérieurs (C) et (A) pour la dernière paire.

NOTE: Utilisez la traverse supérieure de tête de lit (F) qui porte l'étiquette entre les pieds supérieurs (A) et (C). Voyez l'illustration pour vous assurer de bien placer l'étiquette.

LITS SUPERPOSÉS ET LITS JUMEAU/GRAND

DA7499E / DA7499W / DA7499G

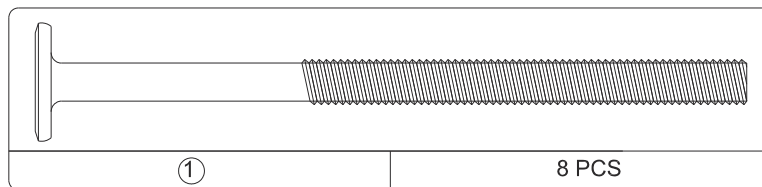
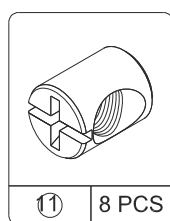
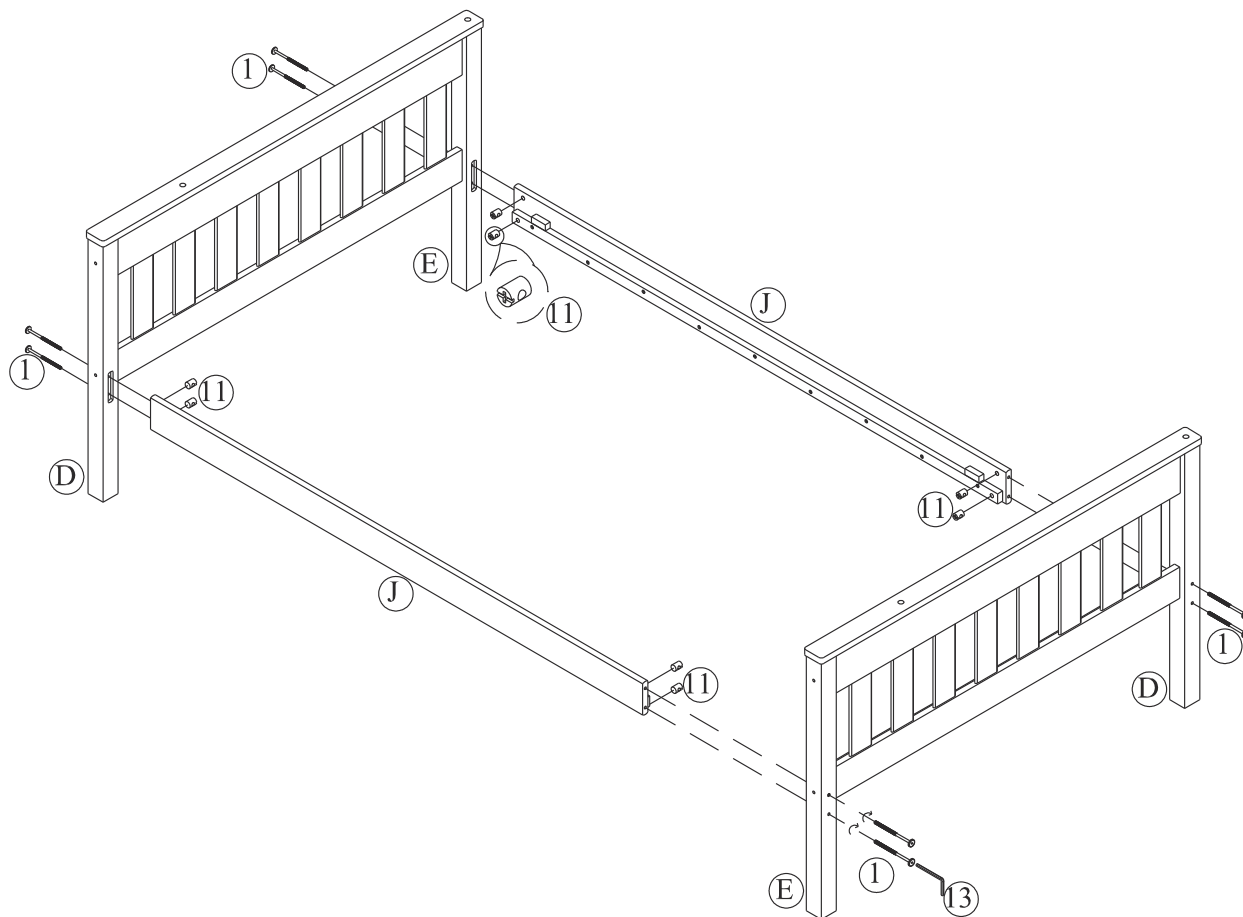

ÉTAPE 3

Insérez des écrous à manchon fileté (10) dans les côtés de lit inférieurs (J) comme illustré.

Fixez les deux têtes de lit avec les pieds inférieurs (D et E) aux côtés de lit inférieurs (J) à l'aide de connecteurs (1) et la clé Allen (12).

Note: Celle-ci est la couchette inférieure.

LITS SUPERPOSÉS ET LITS JUMEAU/GRAND

DA7499E / DA7499W / DA7499G

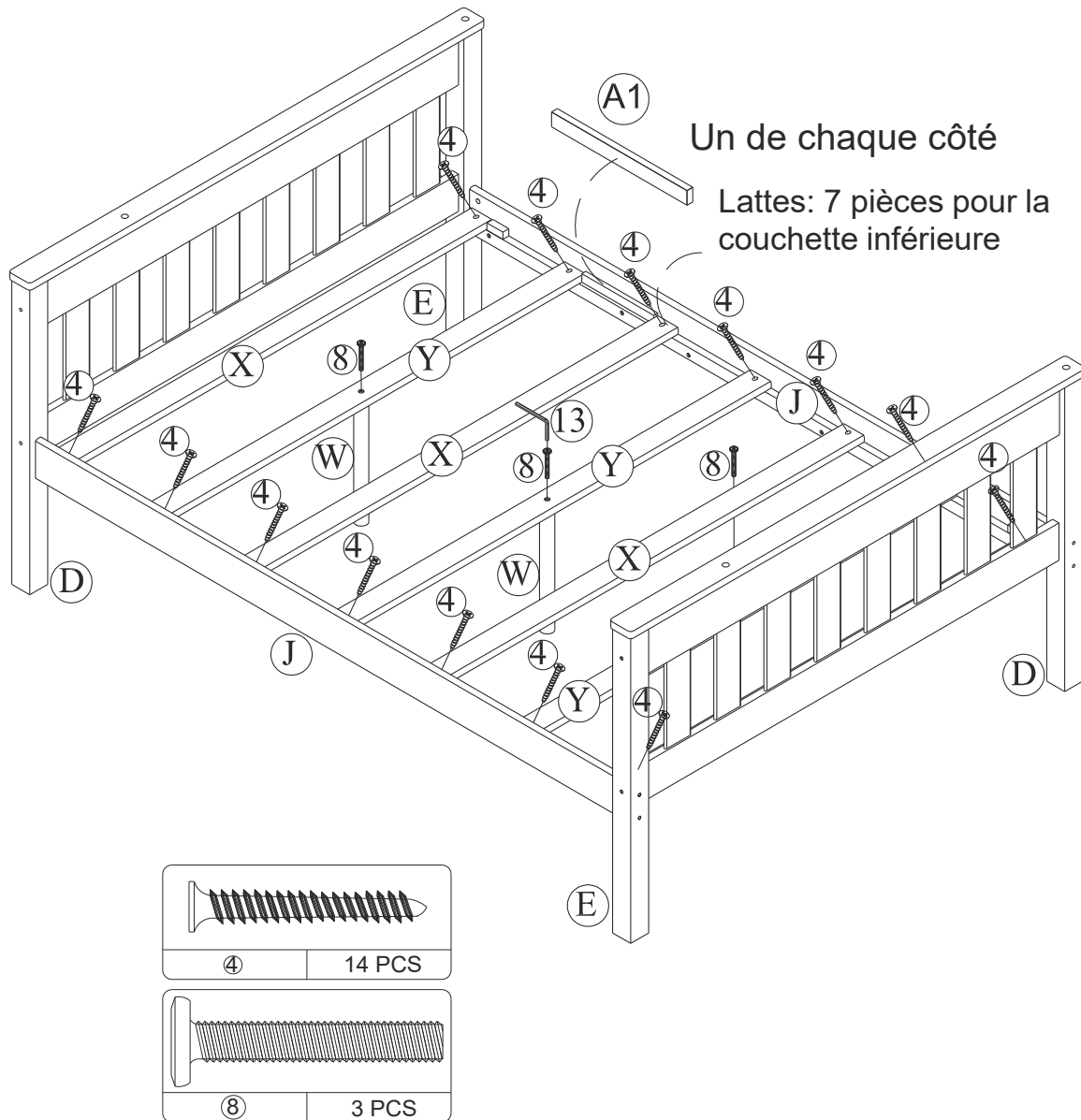

ÉTAPE 4

Fixez les pieds de support (W) aux lattes inférieures (Y) de la couchette inférieure avec des boulons à tête hexagonale (8) comme illustré.

Fixez une latte inférieure (X) aux côtés de lit inférieurs (J) avec des vis à bois à tête plate (4). Assurez-vous que la latte touche les pieds au coin (le plus proche possible de la tête de lit). Fixez les autres lattes (X et Y) aux côtés de lit inférieurs (J) avec des vis à bois à tête plate (4) à l'aide d'un tournevis Phillips (non inclus). Utilisez les barres d'espacement (A1) pour séparer les lattes de manière égale comme illustré.

NOTE: Si vous remarquez que l'une des lattes (X et Y) n'est pas parfaitement plate, assurez-vous de les fixer de façon à ce que la courbe des lattes (X et Y) soit placée vers le haut au milieu et qu'elle descende vers les extrémités.

LITS SUPERPOSÉS ET LITS JUMEAU/GRAND

DA7499E / DA7499W / DA7499G

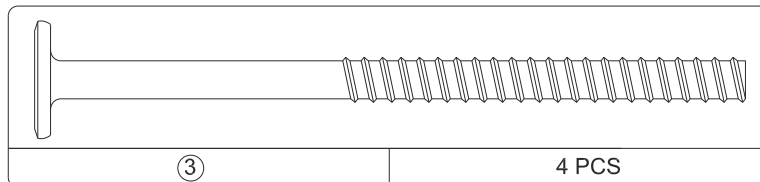
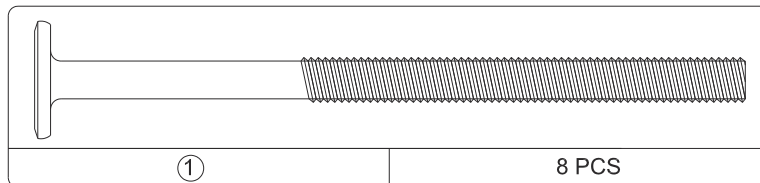
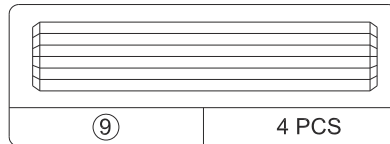
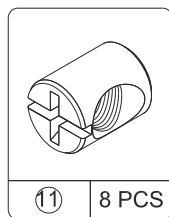
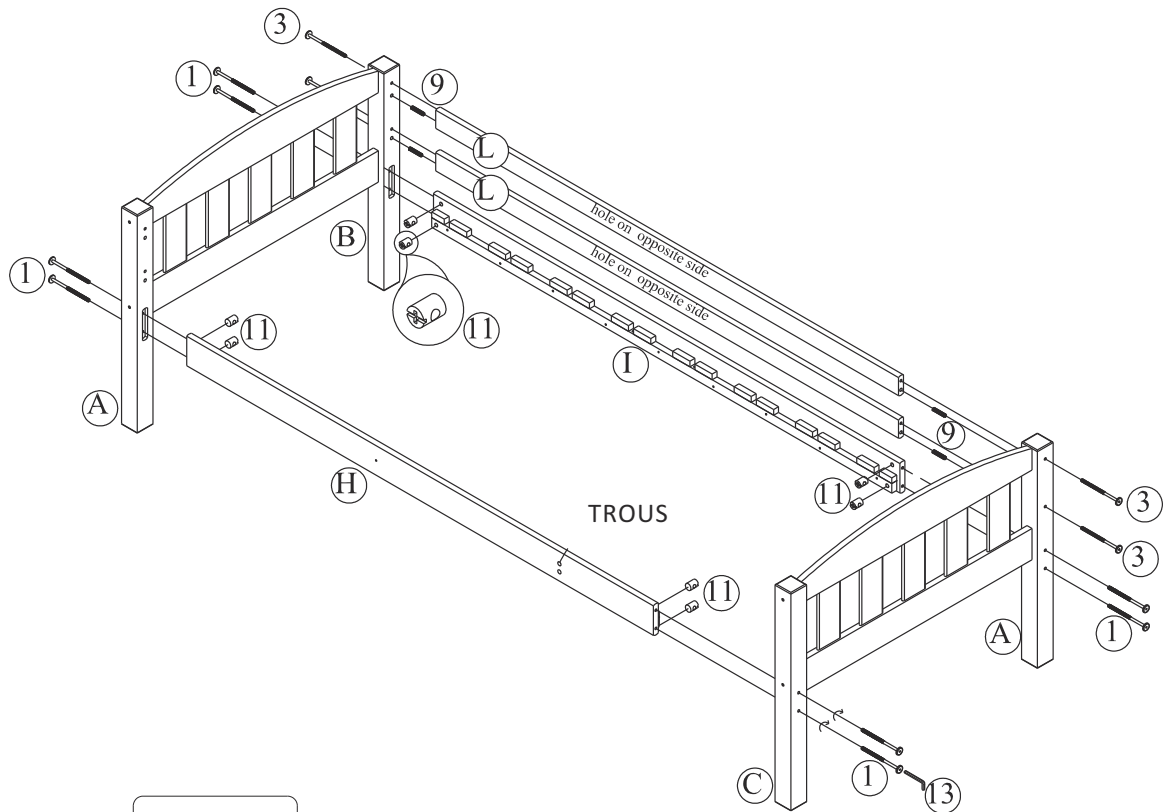

ÉTAPE 5

Insérez des goujons de bois (9) dans chacune des extrémités des barrières longues (L).

Insérez des écrous à manchon fileté (10) dans les côtés de lit supérieurs (H et I).

Fixez deux barrières longues (L) et deux côtés de lit supérieurs (H et I) aux pieds supérieurs (A et B) et (A et C) comme illustré, à l'aide de connecteurs (1) et (3).

Utilisez la clé Allen (12) pour serrer tous les connecteurs.

Celle-ci est la couchette supérieure.

LITS SUPERPOSÉS ET LITS JUMEAU/GRAND

DA7499E / DA7499W / DA7499G

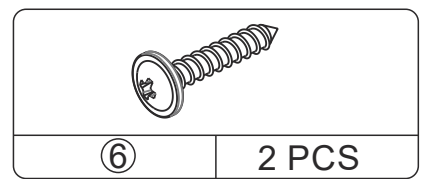
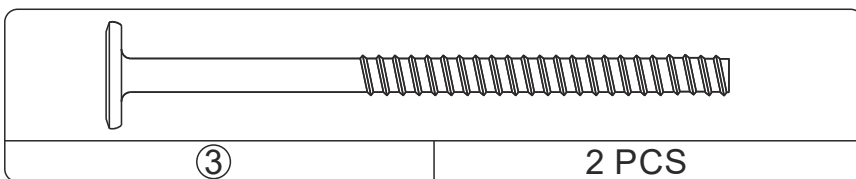
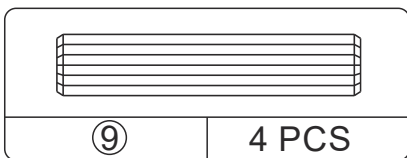
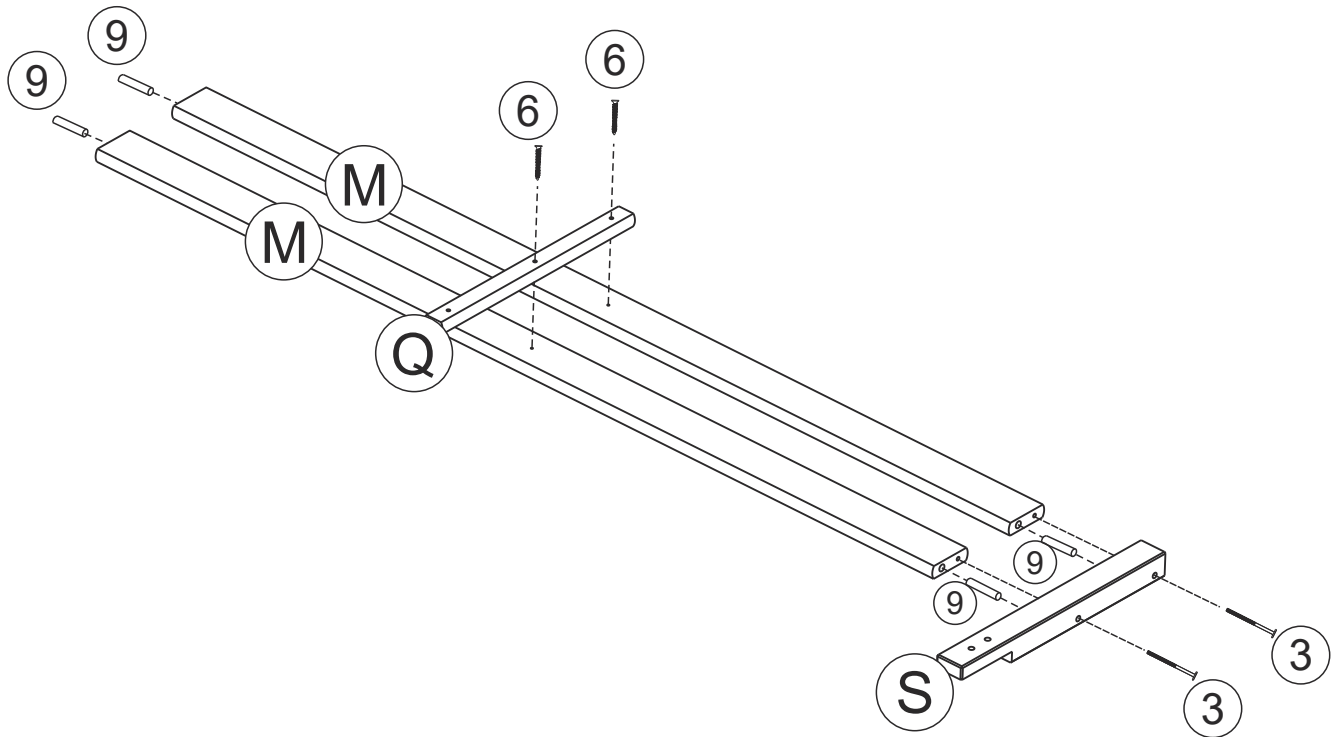

ÉTAPE 6

Insérez des goujons (9) dans chacune des extrémités des barrières courtes (M). Fixez le pied de barrière courte (S) et un pied de barrière (Q) aux barrières courtes (M) à l'aide de connecteurs à bois (3) et de vis à bois à tête plate (6).

LITS SUPERPOSÉS ET LITS JUMEAU/GRAND

DA7499E / DA7499W / DA7499G

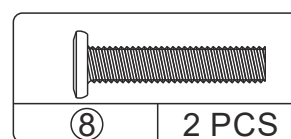
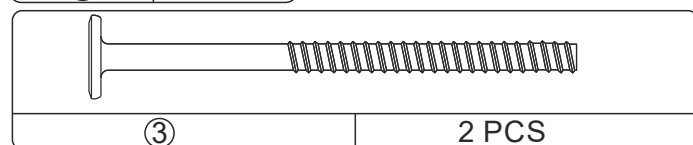
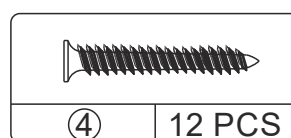
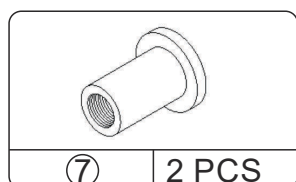
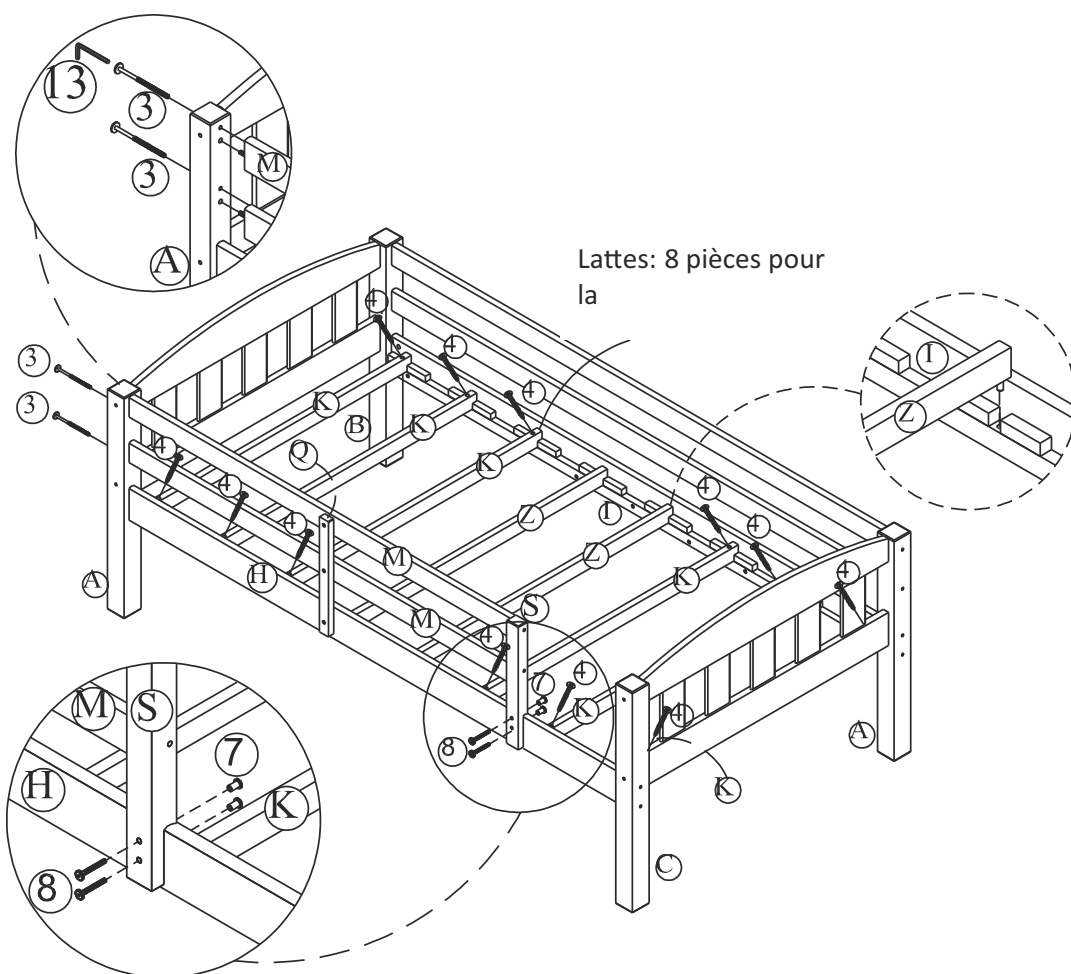

ÉTAPE 7

Fixez la barrière courte déjà assemblée au pied supérieur (A) à l'aide de connecteurs à bois (3), et au côté de lit supérieur (H) à l'aide de boulons à tête hexagonale (8) et de chapeaux à vis hexagonales (7) comme illustré. Utilisez la clé Allen (13) pour serrer les chapeaux à vis (7).

Fixez une latte supérieure (K) aux côtés de lit supérieurs (H et I) de la couchette supérieure à l'aide de vis à bois à tête plate (4). Assurez-vous que la latte soit en contact avec les pieds aux coins (le plus proche possible à la tête de lit). Fixez les autres lattes (K) aux côtés de lit supérieurs (H et I) à l'aide de vis à bois à tête plate (4) et placez les lattes (Z) sur les côtés de lit supérieurs (H et I) comme illustré.

NOTE: Les lattes (K et Z) doivent être fixées de façon à ce que la courbe soit placée vers le haut au milieu et qu'elle descende vers les extrémités.

LITS SUPERPOSÉS ET LITS JUMEAU/GRAND

DA7499E / DA7499W / DA7499G

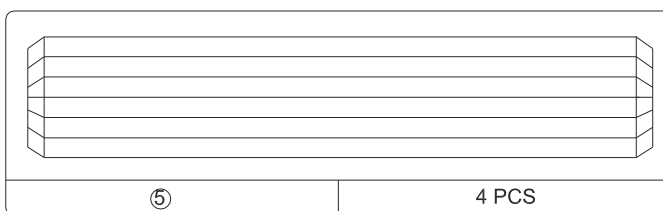
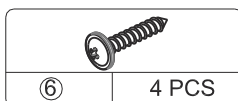
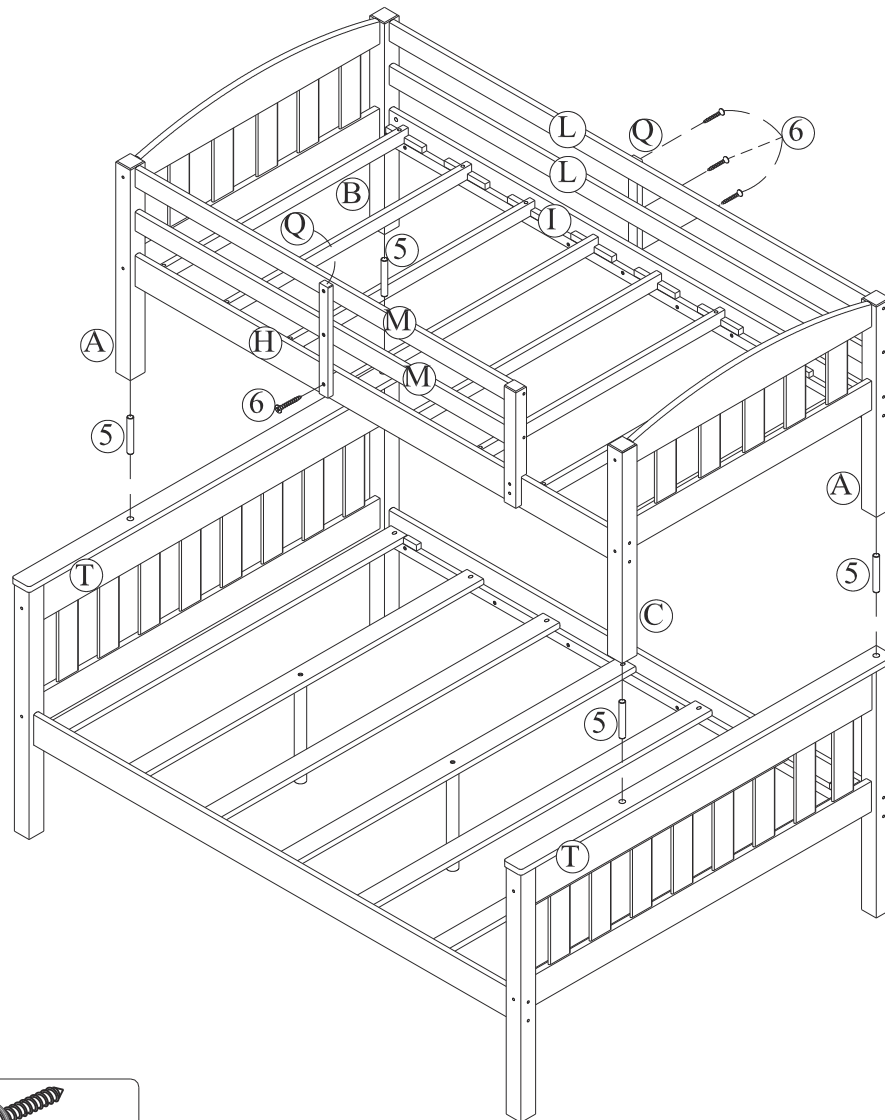

ÉTAPE 8

Fixez l'autre pied de barrière (Q) aux barrières longues (L) et au côté de lit supérieur (I) à l'aide de vis à bois à tête plate (6).

Fixez le pied de barrière (Q) (déjà assemblé à l'étape 6) au côté de lit supérieur (H) à l'aide de vis à bois à tête plate (6) comme illustré.

Placez quatre goujons de bois (5) dans les trous des traverses inférieures de tête de lit (T). Avec l'aide d'une autre personne, montez la couchette supérieure sur la couchette inférieure.

LITS SUPERPOSÉS ET LITS JUMEAU/GRAND

DA7499E / DA7499W / DA7499G

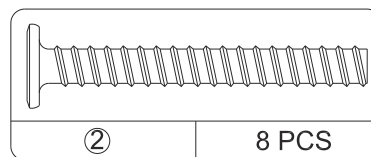
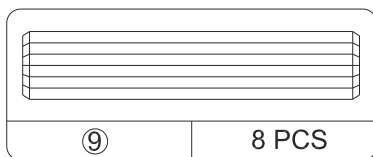
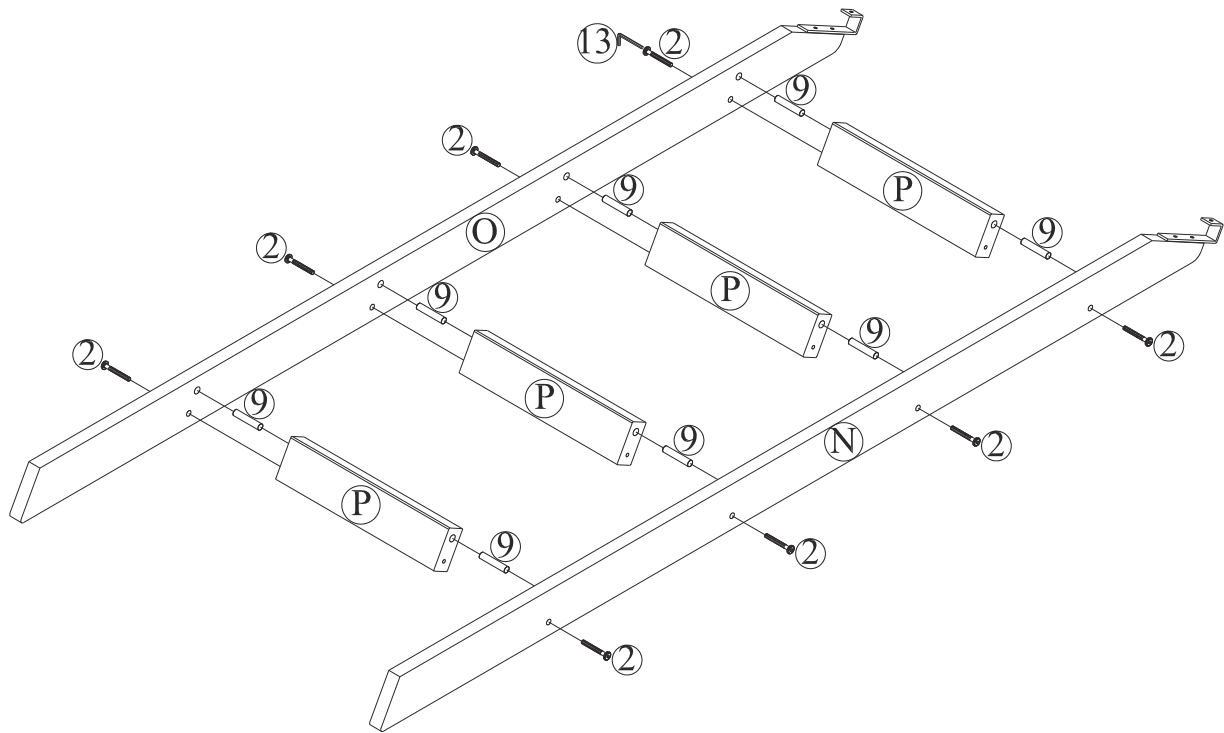

ÉTAPE 9

Insérez des goujons de bois (9) dans les extrémités des marches de l'échelle (P). Fixez le montant gauche de l'échelle (N) et le montant droit de l'échelle (O) aux marches de l'échelle (P) à l'aide de connecteurs à bois (2). Utilisez la clé Allen (13) pour serrer les connecteurs comme illustré.

LITS SUPERPOSÉS ET LITS JUMEAU/GRAND

DA7499E / DA7499W / DA7499G

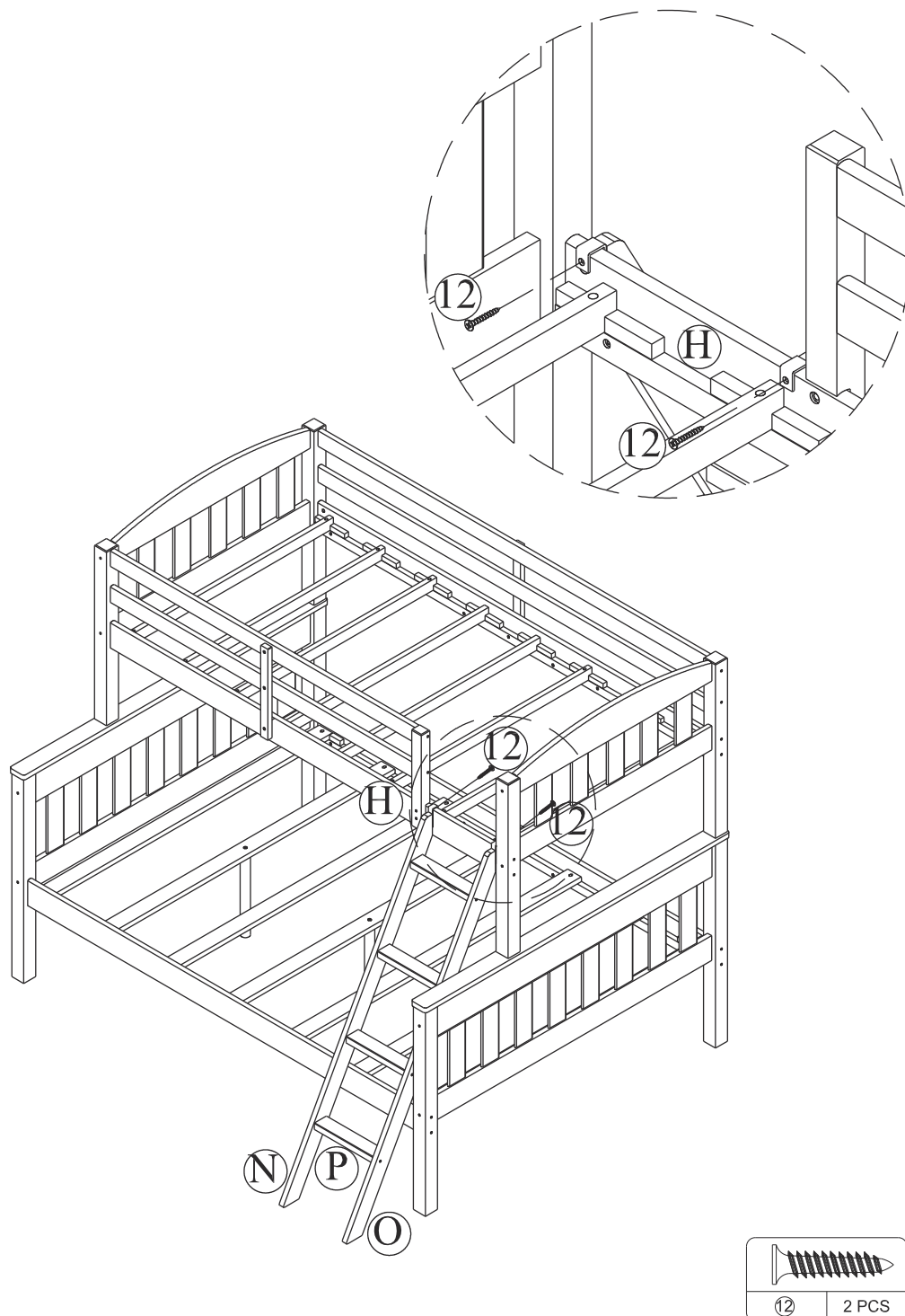

ÉTAPE 10

Fixez l'échelle au côté de lit supérieur (H) à l'aide de vis à tête plate (12) comme illustré.

LITS SUPERPOSÉS ET LITS JUMEAU/GRAND DA7499E / DA7499W / DA7499G

Instructions pour transformer les lits superposés en deux lits

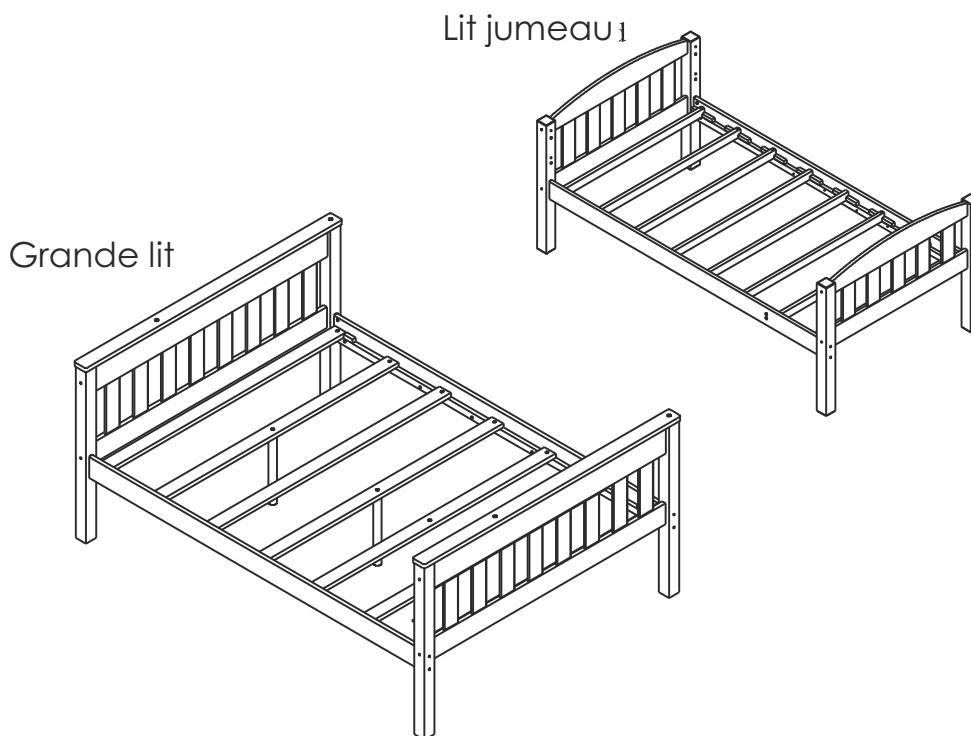
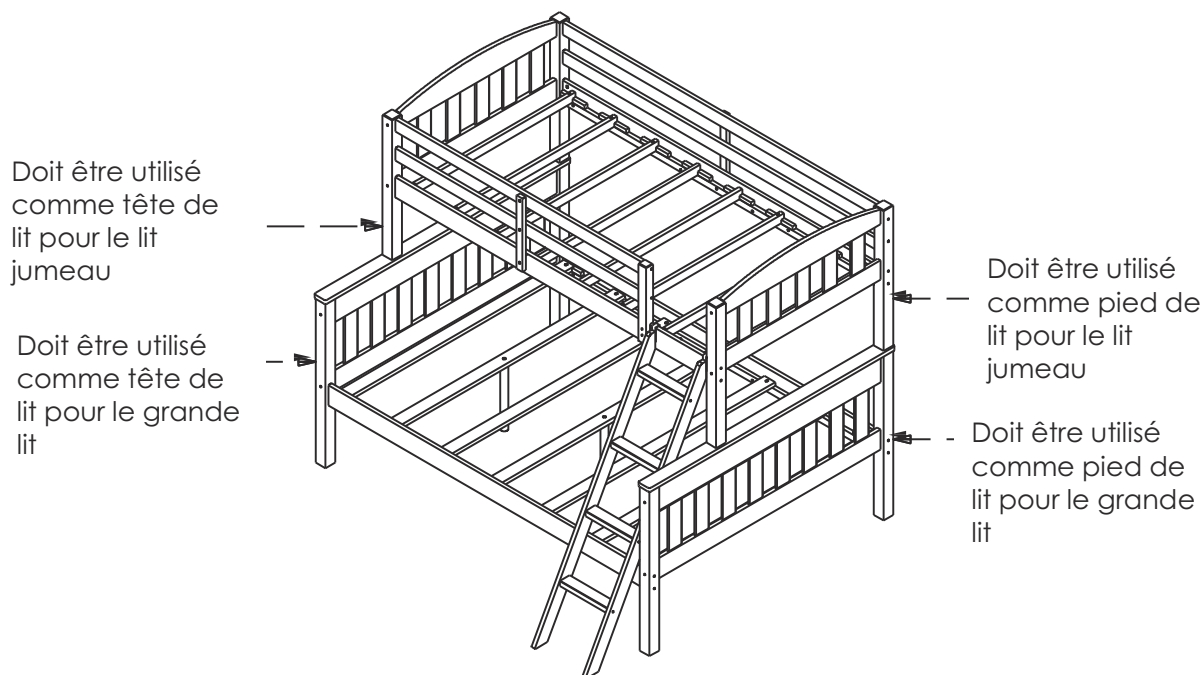

TRANSFORMER LES LITS SUPERPOSÉS EN UN GRAND LIT ET UN LIT JUMEAU

Retirez l'échelle et les barrières.

Avec l'aide d'une autre personne, détachez la couchette supérieure de la couchette inférieure et retirez les goujons de bois des pieds.

LITS SUPERPOSÉS ET LITS JUMEAU/GRAND

DA7499E / DA7499W / DA7499G

! ATTENTION: Cette unité est destinée à être utilisée seulement avec des produits et/ou les poids maximum indiqués. L'utilisation avec d'autres produits et/ou des produits plus lourds que les poids maximum indiqués peut entraîner une instabilité ou causer des blessures.

NE PERMETTEZ PAS LE JEUX DE BATAILLE SUR OU EN DESSOUS DU LIT ET INTERDISEZ AUX ENFANTS DE SAUTER SUR LE LIT.

NE PERMETTEZ PAS AUX ENFANTS DE MOINS DE 6 ANS DE DORMIR SUR LA COUCHETTE SUPÉRIEURE. LE LIT EST CONÇU POUR DES ENFANTS À PARTIR DE 6 ANS JUSQU'AU DÉBUT DE L'ADOLESCENCE.

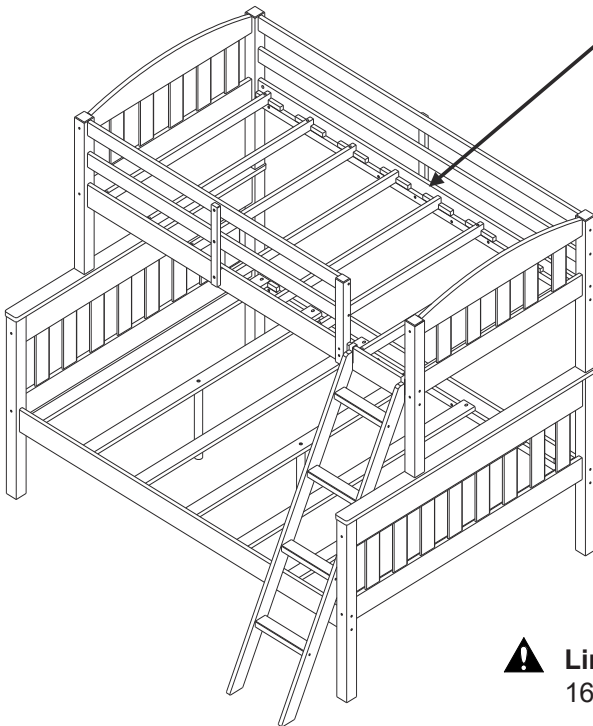

AFIN D'ÉVITER DES BLESSURES, UTILISEZ SEULEMENT DES MATELAS À RESSORTS SUR LES DEUX COUCHETTES.

! Limite de Poids:
165 Lb / 75 kg Par Niveau

Voilà ! Vous avez terminé d'assembler vos lits superposés.

NE PAS RETOURNER CE PRODUIT AU DÉTAILLANT.

Si une pièce est manquante ou endommagée, contactez notre Service à la clientèle. Nous remplacerons la pièce **GRATUITEMENT**.

No de tel. : 1-800-267-1739
Courriel : cs@dhpfniture.com